

Bullet Wall Mount

TR-WM06-C-IN

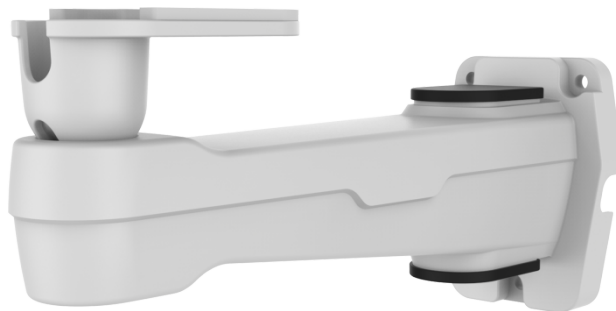

Specifications

Model	TR-WM06-C-IN
Bracket	
Application	wall installation for Bullet
Bracket Dimensions	193mmx60mmx77mm(7.6" x 2.4"x 3.0")
Bracket Weight	0.2kg(0.44lb)
Bracket Material	Aluminum alloy

Dimensions

Aggregate product size diagram using "main model" as an example

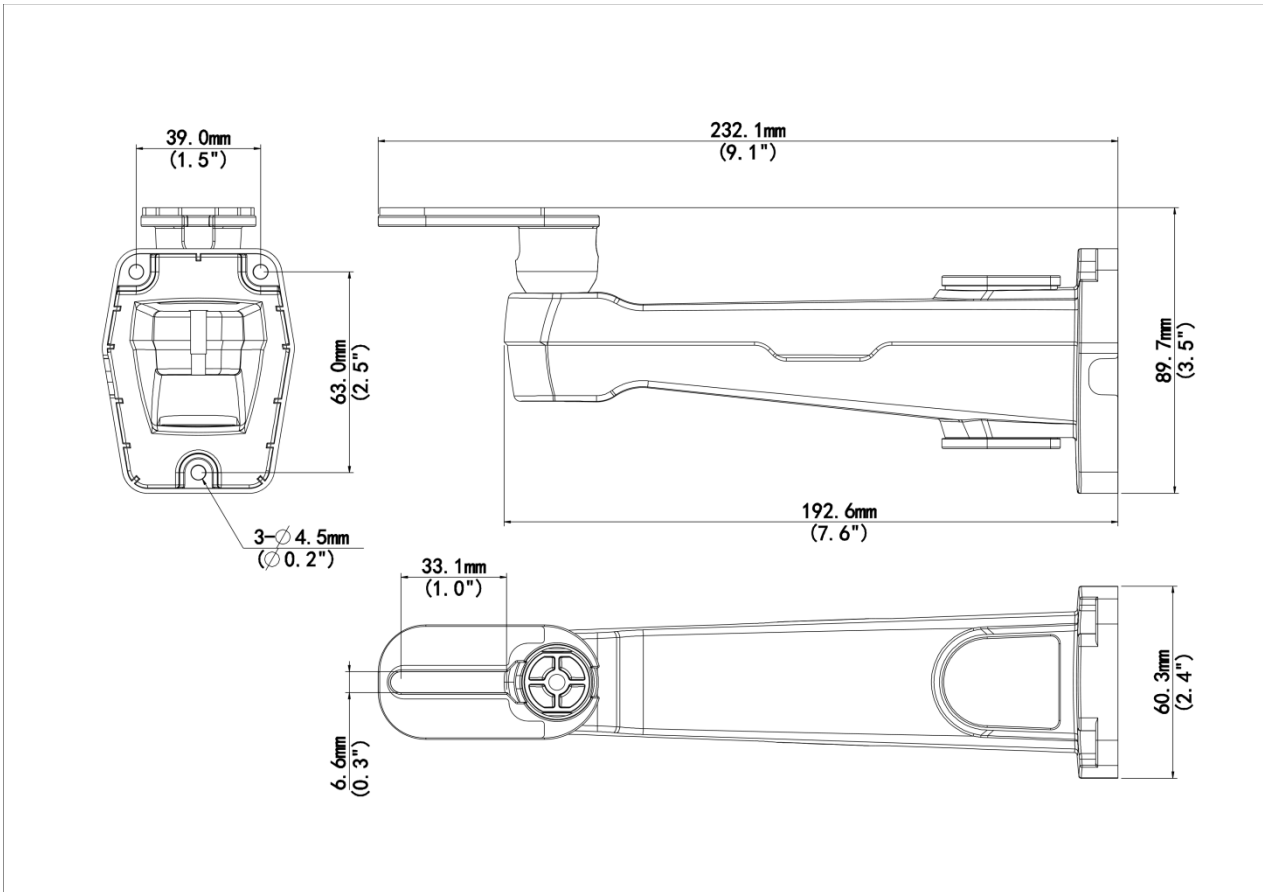

Accessories

HS-217S-B-NB

17" Outdoor Box Camera Housing (Standard Edition)

HS-217SHB-B-NB

Outdoor Enhanced Integrated Housing (17 Inch, Plastic Sunshade)

HS-217SHB-IR-B-NB

Outdoor Enhanced IR Integrated Housing (17 Inch, Plastic Sunshade, IR)

TR-WM06-C-IN

Wall Mounting Bracket for 6-inch Bullet Camera



TR-UM06-A-IN

Bullet Camera Desktop Bracket

TR-WM06-I-IN

Wall Mounting Bracket for 28&29 Housing



TR-UV06-A-IN

3D Adjustable Mounting Bracket

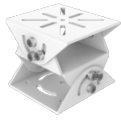

TR-UP06-IN

Universal Pole Mounting Bracket



Zhejiang Uniview Technologies Co., Ltd.

No. 369, Xietong Road, Xixing Sub-district, Binjiang District, Hangzhou City, 310051, Zhejiang Province, China

Email: overseasbusiness@uniview.com; globalsupport@uniview.com

<http://www.uniview.com>

©2023-2025 Zhejiang Uniview Technologies Co., Ltd. All rights reserved.

*Product specifications and availability are subject to change without notice.

*Despite our best efforts, technical or typographical errors may exist in this document. Uniview cannot be held responsible for any such errors and reserves the right to change the contents of this document without prior notice.