

5MP HD Intelligent LightHunter IR Fixed Eyeball Network Camera

IPC3615SS-ADF28(40)K-I1

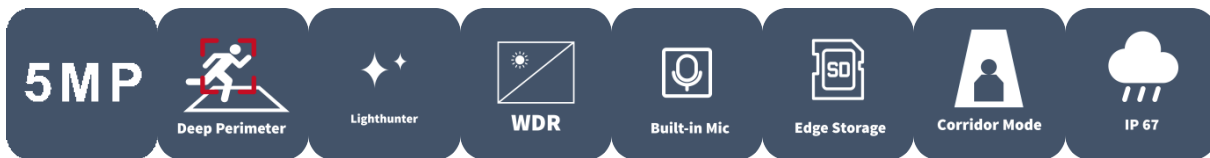

Features

- High quality image with 5MP, 1/2.7" CMOS sensor
- 5MP (2880*1620)@ 30/25(default)fps; 4MP (2560*1440)@ 30/25fps; 3MP (2304*1296) @30/25fps; 2MP (1920*1080) @30/25fps
- Ultra 265, H.265, H.264, MJPEG
- Intelligent perimeter protection, include cross line, intrusion, enter area, leave area detection
- Based on target classification, smart intrusion prevention significantly reduce false alarm caused by leaves, birds and lights etc., accurately focus on human and, motor vehicle and non-motor vehicle
- Intelligent People Flow Counting and Crowd Density Monitoring
- Smart intrusion prevention with Color retrieval
- Auto Scene Match (ASM)(Only WDR)
- LightHunter technology ensures ultra-high image quality in low illumination environment
- 130dB true WDR technology enables clear image in strong light scene
- Support 9:16 Corridor Mode
- Built-in Mic
- Smart IR, up to 40m (131ft) IR distance

- Supports 512 G Micro SD card
- IP67 protection

Dimensions

Aggregate product size diagram using "main model" as an example

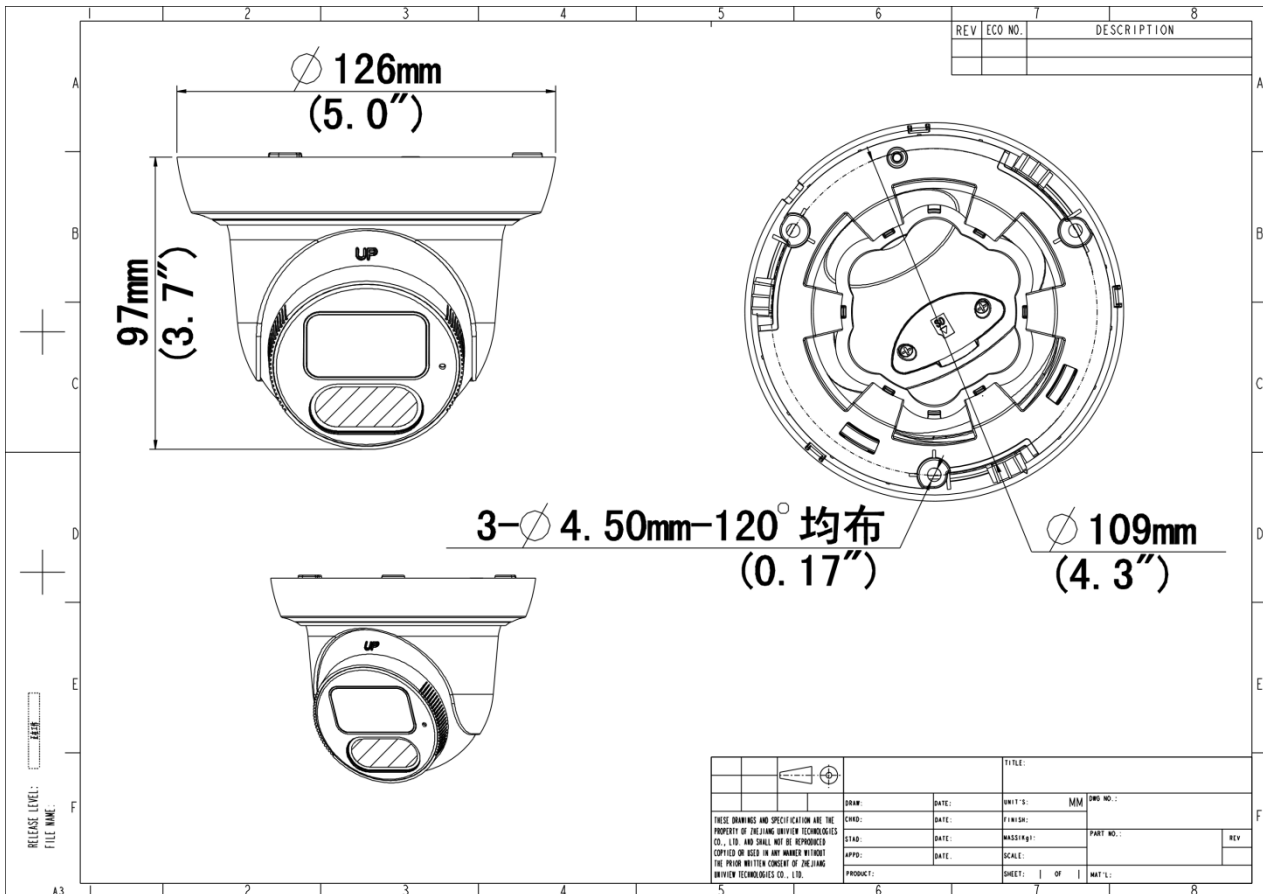

Accessories

TR-JB03-H-IN

Junction Box for Metal Turret Camera
(Support wiring from behind)



TR-JB07/WM03-F-IN

Wall Mounting Assembling Bracket with Back Hole for 3 Inch Hemisphere



TR-WM03-B-IN

Wall Mounting Assembling Bracket for 3 Inch Hemisphere



TR-A01-IN

NPT 3/4" Waterproof Cable Gland



TR-UP06-IN

Universal Pole Mounting Bracket



TR-UC08-C

Bullet&Dome Corner Mounting Bracket



TR-SE24-IN

Dome Pendant Mounting Pole 200m

m



TR-SE24-A-IN

Dome Pendant Mounting Pole 500m

m



TR-CM24-IN

Dome Pendant Mounting Bracket(Indoor)



Zhejiang Uniview Technologies Co., Ltd.

No. 369, Xietong Road, Xixing Sub-district, Binjiang District, Hangzhou City, 310051, Zhejiang Province, China

Email: overseasbusiness@uniview.com; globalsupport@uniview.com

<http://www.uniview.com>

©2024-2025 Zhejiang Uniview Technologies Co., Ltd. All rights reserved.

*Product specifications and availability are subject to change without notice.

*Despite our best efforts, technical or typographical errors may exist in this document. Uniview cannot be held responsible for any such errors and reserves the right to change the contents of this document without prior notice.