

Fixed Dome Indoor Pendant Mount

TR-CM24-IN



Specifications

Bracket	Description
Application	Pendant mount for IPC323X Series fixed dome
Bracket Dimensions	Φ 110mm*223.5mm (4.33" x8.80")
Bracket Weight	0.25kg(0.55lb)
Bracket Material	Aluminum alloy

Dimensions

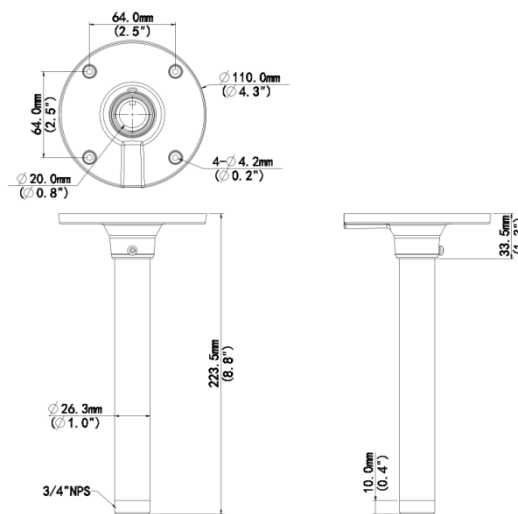

Accessories

TR-CM24-IN

Dome Pendant Mounting Bracket(Indoor)



TR-SE24-IN

Dome Pendant Mounting Pole 200m

m



TR-SE24-A-IN

Dome Pendant Mounting Pole 500m

m



TR-A01-IN

NPT 3/4" Waterproof Cable Gland



TR-JB08

Junction Box for 322x Dual-lens Dome



Zhejiang Uniview Technologies Co., Ltd.

No. 369, Xietong Road, Xixing Sub-district, Binjiang District, Hangzhou City, 310051, Zhejiang Province, China

Email: overseasbusiness@uniview.com; globalsupport@uniview.com

<http://www.uniview.com>

©2023-2024 Zhejiang Uniview Technologies Co., Ltd. All rights reserved.

*Product specifications and availability are subject to change without notice.

*Despite our best efforts, technical or typographical errors may exist in this document. Uniview cannot be held responsible for any such errors and reserves the right to change the contents of this document without prior notice.