

Dual-Lens Video Doorbell

Quick Guide



V1.05

1 Packing List

Contact your local dealer if the package is damaged or incomplete. The package contents may vary with device model.

No.	Name	Qty	Unit
1	Dual-lens video doorbell	1	PCS
2	Power kit	1	PCS
3	Fuse kit	1	Set
4	Power cable kit	1	Set
5	Power kit connection cable	1	Set
6	Flat mount bracket	1	PCS
7	Inclined mount bracket	1	PCS
8	Detaching pin	1	PCS
9	Screw components	1	Set
10	Drill template	1	PCS
11	Installation foam	1	PCS
12	Product documents	1	Set

2 Product Introduction

The appearance, dimensions, and structure may vary with device model.

2.1 Dimensions and Structure

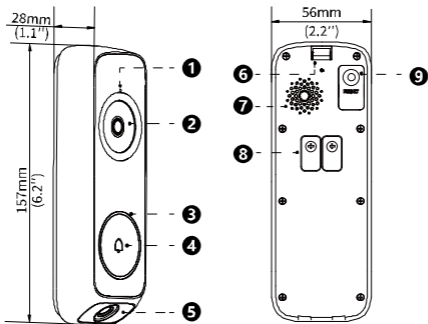

1. Microphone	2. Main camera
3. LED indicator	4. Doorbell button <ul style="list-style-type: none">• When the doorbell is powered on, press and hold the button for 2 seconds to configure the network.• Press to make a call.
5. Sub camera (with illuminators on both sides)	6. Disassembly clip: After the doorbell is installed, you can press the clip using the detaching pin to remove the doorbell from the bracket.
7. Speaker	8. Power connection terminal
9. Reset button Press and hold the button until you hear a beep, then release the button, and the device will begin to restore the factory defaults. Wait until the indicator flashes red, which means that the reset is successful.	

2.2 Indicator and Audio Prompt

Indicator Status	Audio Prompt	Description
Steady red	Two beeps	The doorbell is restoring factory defaults.
Blinking red (once per second)	Wi-Fi connection failed.	The doorbell failed to connect to Wi-Fi.
	-	The doorbell failed to connect to EZCloud.
Blinking green (once per second)	Please connect the device to the network with the app	The network configuration automatically starts upon the first startup (to configure the network later, press and hold the doorbell button for 2 seconds).
	-	<ul style="list-style-type: none">• The doorbell is connecting to Bluetooth.• The call is hung up on the app.
Blinking green (twice per second)	Ding-dong	The doorbell is connected to EZCloud.
	Wi-Fi connected.	The doorbell is connected to Wi-Fi.
Blinking green slowly	Dudu	The doorbell is making a call.
Steady green	-	The call is answered on the app.
-	Added successfully.	The doorbell has been added to the app.

2.3 Paired Devices

The doorbell can be used with the following chimes.

- Wireless chime: ED-R1
- Mechanical chime: Only LA11WH-1, C210-W

3 Doorbell Installation

3.1 Installation Preparation



WARNING!

Be sure to disconnect the doorbell from power before installation.

1 Installation Position

- It is recommended to install the doorbell on the wall next to the main gate.
- It is recommended to install the doorbell as close to the router as possible, and avoid too many walls in between; otherwise, Wi-Fi signals may be weakened.

2 Wiring

- If the doorbell uses a mechanical chime, choose **Mechanical Chime** when adding the doorbell on the app.

Doorbell

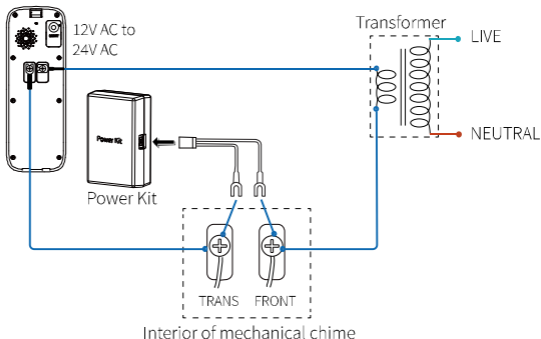

- If the doorbell uses a wireless chime, choose **Wireless Chime** when adding the doorbell on the app.

Doorbell

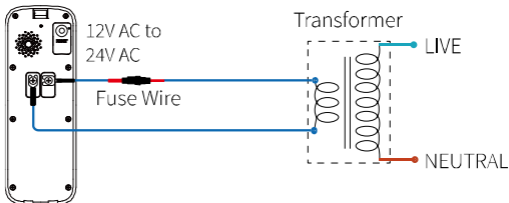

3 Tools

Please prepare antistatic wrist strap or gloves, electric drill, hammer, #1 Phillips screwdriver, and #2 Phillips screwdriver.

3.2 (Optional) Power Kit Installation



NOTE!

The power kit is required when the doorbell is used with a mechanical chime.

1. Plug the connector of the power kit connection cables into the power kit.
2. Remove the cover of the mechanical chime, and connect the two U-shaped connectors to the TRANS and FRONT terminals on the mechanical chime.
3. Place the power kit inside the mechanical chime and reinstall the cover.

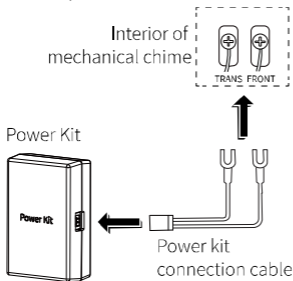

3.3 Doorbell Installation

1. Choose the mount bracket according to the desired viewing angle.

The viewing angle of main camera and sub camera may vary with the used bracket.

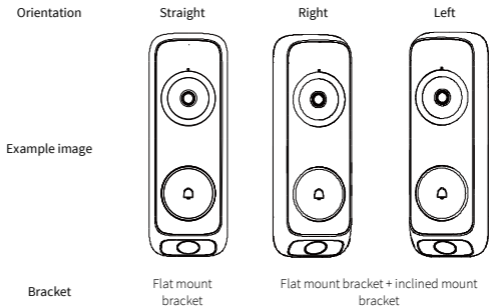

2. (Optional) If the wall is uneven, remove the release paper from the installation foam, and then attach the foam to the back of the bracket.

Attach to Flat Mount Bracket



Attach to Inclined Mount Bracket



3. Attach the drill template to the wall in the correct direction (see the arrow), at the recommended height of 1.2m from the center of the template to the ground.

4. Drill two holes (depth: at least 25mm; diameter: 6mm to 6.5mm) on the wall, and then insert expansion tubes.

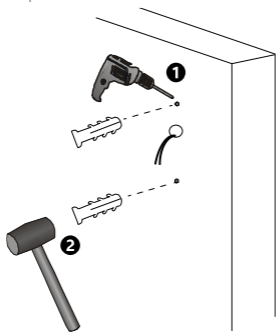

5. Place the flat mount bracket in the correct direction (see the arrow), and lead the cables inside the wall through the bracket hole (if inclined mount is required, place the inclined mount bracket behind the flat mount bracket).
6. Insert the short screws (for the flat mount bracket) or long screws (for the inclined mount bracket) into the expansion tubes using a #2 Phillips screwdriver to secure the bracket to the wall.

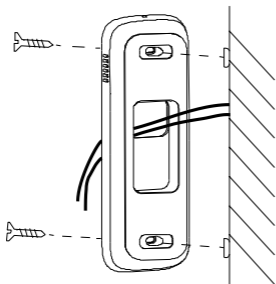

7. Connect cables. The steps may vary with the chime model.

● Mechanical Chime

- (1) Loosen the two screws on the back of the doorbell using a #1 Phillips screwdriver, insert the U-shaped connectors of the two supplied power cables under the two terminal screws respectively, and tighten the screws.
- (2) Connect a power cable on the doorbell to an external power cable by twisting them together and inserting into the wire connector.
- (3) Repeat the step above to connect the other cables.

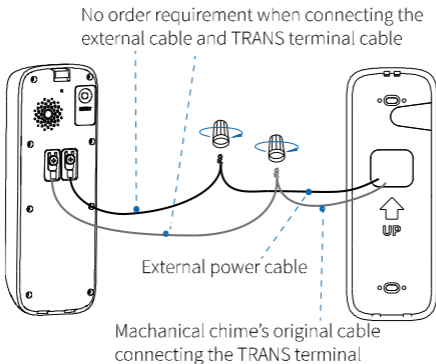

● Wireless Chime

- (1) Repeat the first two steps of the mechanical chime cable connection.
- (2) Connect the two ends of the fuse wire with the doorbell cable and external power cable respectively, and then insert them into the wire connectors one by one.

No order requirement when connecting the external cables

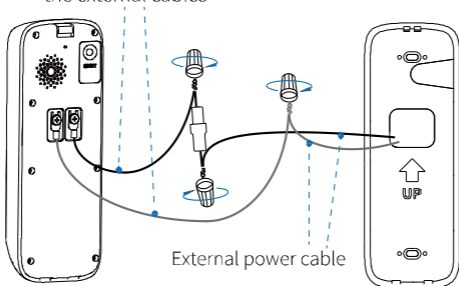

8. Secure the doorbell to the flat mount bracket.

- (1) Align the two notches at the bottom of the doorbell with the protruding parts of the bracket and press the doorbell until it clicks into place.
- (2) Press the top of the doorbell until you hear a click, which indicates that the doorbell has been secured to the bracket.

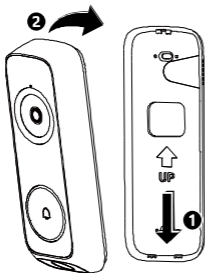

4 Doorbell Startup

Reconnect the doorbell to the power to start it up.

5 Doorbell Detaching



WARNING!

Be sure to disconnect the doorbell from power before detaching it from the bracket.

Use the supplied tool to detach the doorbell from the bracket.

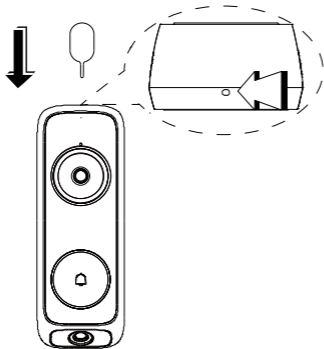

6 Web Login

Default IP address:

192.168.1.13

**Default
username/password:**

admin / 123456

Note:

For security, please set a strong password of at least nine characters including uppercase and lowercase letters, digits, and special characters. You are strongly recommended to regularly change the device password and keep it secure to ensure that only authorized users can log in.

7 Pairing



NOTE!

- Make sure the chime and doorbell are connected to power.
- Make sure your phone is Bluetooth-enabled and connected to Wi-Fi.
- Scan the activation code (located on the back of the doorbell or quick guide cover) using the app to add the device. Please take care of the activation code sticker to prevent it from aging/peeling off or losing it.



WARNING!

Incorrect chime mode selection may damage the device.

1 App Installation and Login

1. Scan the QR code, download and install the app.



2. Follow the on-screen prompts to sign up for an account and log in to the app.

2 Doorbell Adding and Network Configuration

1. The network configuration automatically starts upon the first startup (to configure the network later, press and hold the doorbell button for 2 seconds), and the indicator flashes green once per second and an audio prompt plays, **Please connect the device to the network with the app.**
2. Use the app to scan the activation code on the back of the doorbell or on the cover of this guide, add the doorbell to the app, and follow the on-screen prompts to configure the network.

After the network configuration is complete, the doorbell indicator flashes green twice per second and an audio prompt plays, **Wi-Fi connected.**

Then, the doorbell is added to the app and an audio prompt plays, **Added successfully.**

3 Pairing

Tap ... in the upper-right corner of the doorbell on the app, go to **Chime Settings > Add Chime**, and follow the on-screen prompts to pair the doorbell with the chime.

After the doorbell is paired with the wireless chime ED-R1, the chime beeps and then the indicator is steady green.

Disclaimer and Safety Warnings

Copyright Statement

©2024-2025 Zhejiang Uniview Technologies Co., Ltd. All rights reserved.

No part of this manual may be copied, reproduced, translated or distributed in any form or by any means without prior consent in writing from Zhejiang Uniview Technologies Co., Ltd (referred to as Uniview or us hereafter).

The product described in this manual may contain proprietary software owned by Uniview and its possible licensors. Unless permitted by Uniview and its licensors, no one is allowed to copy, distribute, modify, abstract, decompile, disassemble, decrypt, reverse engineer, rent, transfer, or sublicense the software in any form or by any means.

Trademark Acknowledgements

 are trademarks or registered trademarks of Uniview.

All other trademarks, products, services and companies in this manual or the product described in this manual are the property of their respective owners.

Export Compliance Statement

Uniview complies with applicable export control laws and regulations worldwide, including that of the People's Republic of China and the United States, and abides by relevant regulations relating to the export, re-export and transfer of hardware, software and technology. Regarding the product described in this manual, Uniview asks you to fully understand and strictly abide by the applicable export laws and regulations worldwide.

EU Authorised Representative

UNV Technology EUROPE B.V. Treubstraat 1, 2288 EG, Rijswijk, Netherlands.

If you have any feedback, please contact us at service@uniview.com.

Privacy Protection Reminder

Uniview complies with appropriate privacy protection laws and is committed to protecting user privacy. You may want to read our full privacy policy at our website and get to know the ways we process your personal information. Please be aware, using the product described in this manual may involve the collection of personal information such as face, fingerprint, license plate number, email, phone number, GPS. Please abide by your local laws and regulations while using the product.

About This Manual

- This manual is intended for multiple product models, and the photos, illustrations, descriptions, etc. in this manual may be different from the actual appearances, functions, features, etc. of the product.
- This manual is intended for multiple software versions, and the illustrations and descriptions in this manual may be different from the actual GUI and functions of the software.
- Despite our best efforts, technical or typographical errors may exist in this manual. Uniview cannot be held responsible for any such errors and reserves the right to change the manual without prior notice.
- Users are fully responsible for the damages and losses that arise due to improper operation.
- Uniview reserves the right to change any information in this manual without any prior notice or indication. Due to such reasons as product version upgrade or regulatory requirement of relevant regions, this manual will be periodically updated.

Disclaimer of Liability

- The product described in this manual is provided on an "as is" basis. Unless required by applicable law, this manual is only for informational purpose, and all statements, information, and recommendations in this manual are presented without warranty of any kind, expressed or implied, including, but not limited to, merchantability, satisfaction with quality, fitness for a particular purpose, and noninfringement.

- To the extent allowed by applicable law, in no event shall Uniview's total liability to you for all damages for the product described in this manual (other than as may be required by applicable law in cases involving personal injury) exceed the amount of money that you have paid for the product.
- Users must assume total responsibility and all risks for connecting the product to the Internet, including, but not limited to, network attack, hacking, and virus. Uniview strongly recommends that users take all necessary measures to enhance the protection of network, device, data and personal information. Uniview disclaims any liability related thereto but will readily provide necessary security related support.
- To the extent not prohibited by applicable law, in no event will Uniview and its employees, licensors, subsidiary, affiliates be liable for results arising out of using or inability to use the product or service, including, not limited to, loss of profits and any other commercial damages or losses, loss of data, procurement of substitute goods or services; property damage, personal injury, business interruption, loss of business information, or any special, direct, indirect, incidental, consequential, pecuniary, coverage, exemplary, subsidiary losses, however caused and on any theory of liability, whether in contract, strict liability or tort (including negligence or otherwise) in any way out of the use of the product, even if Uniview has been advised of the possibility of such damages (other than as may be required by applicable law in cases involving personal injury, incidental or subsidiary damage).

Network Security

Please take all necessary measures to enhance network security for your device.

The following are necessary measures for the network security of your device:

- **Change default password and set strong password:** You are strongly recommended to change the default password after your first login and set a strong password of at least nine characters including all three elements: digits, letters and special characters.
- **Keep firmware up to date:** It is recommended that your device is always upgraded to the latest version for the latest functions and better security. Visit Uniview's official website or contact your local dealer for the latest firmware.
- **The following are recommendations for enhancing network security of your device:**
- **Change password regularly:** Change your device password on a regular basis and keep the password safe. Make sure only the authorized user can log in to the device.
- **Enable HTTPS/SSL:** Use SSL certificate to encrypt HTTP communications and ensure data security.
- **Enable IP address filtering:** Allow access only from the specified IP addresses.
- **Minimum port mapping:** Configure your router or firewall to open a minimum set of ports to the WAN and keep only the necessary port mappings. Never set the device as the DMZ host or configure a full cone NAT.
- **Disable the automatic login and save password features:** If multiple users have access to your computer, it is recommended that you disable these features to prevent unauthorized access.
- **Choose username and password discretely:** Avoid using the username and password of your social media, bank, email account, etc, as the username and password of your device, in case your social media, bank and email account information is leaked.
- **Restrict user permissions:** If more than one user needs access to your system, make sure each user is granted only the necessary permissions.
- **Disable UPnP:** When UPnP is enabled, the router will automatically map internal ports, and the system will automatically forward port data, which results in the risks of data leakage. Therefore, it is recommended to disable UPnP if HTTP and TCP port mapping have been enabled manually on your router.
- **Multicast:** Multicast is intended to transmit video to multiple devices. If you do not use this function, it is recommended you disable multicast on your network.
- **Check logs:** Check your device logs regularly to detect unauthorized access or abnormal operations.
- **Isolate video surveillance network:** Isolating your video surveillance network with other service networks helps prevent unauthorized access to devices in your security system from other service networks.

- **Physical protection:** Keep the device in a locked room or cabinet to prevent unauthorized physical access.
- **SNMP:** Disable SNMP if you do not use it. If you do use it, then SNMPv3 is recommended.

Learn More

You may also obtain security information under Security Response Center at Uniview's official website.

Safety Warnings

The device must be installed, serviced and maintained by a trained professional with necessary safety knowledge and skills. Before you start using the device, please read through this guide carefully and make sure all applicable requirements are met to avoid danger and loss of property.

Storage, Transportation, and Use

- Store or use the device in a proper environment that meets environmental requirements, including and not limited to, temperature, humidity, dust, corrosive gases, electromagnetic radiation, etc.
- Make sure the device is securely installed or placed on a flat surface to prevent falling.
- Unless otherwise specified, do not stack devices.
- Ensure good ventilation in the operating environment. Do not cover the vents on the device. Allow adequate space for ventilation.
- Protect the device from liquid of any kind.
- Make sure the power supply provides a stable voltage that meets the power requirements of the device. Make sure the power supply's output power exceeds the total maximum power of all the connected devices.
- Verify that the device is properly installed before connecting it to power.
- Do not remove the seal from the device body without consulting Uniview first. Do not attempt to service the product yourself. Contact a trained professional for maintenance.
- Always disconnect the device from power before attempting to move the device.
- Take proper waterproof measures in accordance with requirements before using the device outdoors.

Power Requirements

- Install and use the device in strict accordance with your local electrical safety regulations.
- Use a UL certified power supply that meets LPS requirements if an adapter is used.
- Use the recommended cordset (power cord) in accordance with the specified ratings.
- Only use the power adapter supplied with your device.
- Use a mains socket outlet with a protective earthing (grounding) connection.
- Ground your device properly if the device is intended to be grounded.

Battery Use Caution

- When battery is used, avoid:
 - Extremely high or low temperature and air pressure during use, storage and transportation.
 - Battery replacement.
- Use the battery properly. Improper use of the battery such as the following may cause risks of fire, explosion or leakage of flammable liquid or gas.
 - Replace battery with an incorrect type;
 - Dispose of a battery into fire or a hot oven, or mechanically crushing or cutting of a battery;
- Dispose of the used battery according to your local regulations or the battery manufacturer's instructions.

Avertissement de l'utilisation de la batterie

- Lorsque utiliser la batterie, évitez:
 - Température et pression d'air extrêmement élevées ou basses pendant l'utilisation, le stockage et le transport.
 - Remplacement de la batterie.
- Utilisez la batterie correctement. Mauvaise utilisation de la batterie comme celles mentionnées ici, peut entraîner des risques d'incendie, d'explosion ou de fuite liquide de gaz inflammables.
 - Remplacer la batterie par un type incorrect;
 - Disposer d'une batterie dans le feu ou un four chaud, écraser mécaniquement ou couper la batterie;

- Disposer la batterie utilisée conformément à vos règlements locaux ou aux instructions du fabricant de la batterie.
- Personal safety warnings:
 - Chemical Burn Hazard. This product contains a coin cell battery. Do NOT ingest the battery. It can cause severe internal burns and lead to death.
 - Keep new and used batteries away from children.
 - If the battery compartment does not close securely, stop using the product and keep it away from children.
 - If you think batteries might have been swallowed or placed inside any part of the body, seek immediate medical attention.
- Avertissements de sécurité personnelle:
 - Risque de brûlure chimique. Ce produit contient une batterie de cellules. N'ingérer pas la batterie. Si la batterie de cellule est avalée, elle peut causer de graves brûlures internes en seulement 2 heures et peut entraîner la mort.
 - Gardez les batteries nouvelles ou utilisées à l'écart des enfants.
 - Si le compartiment de la batterie ne se ferme pas en toute sécurité, cessez d'utiliser le produit et gardez-le à l'écart des enfants.
 - Si vous pensez que des piles ont pu être avalées ou placées à l'intérieur d'une partie du corps, consultez immédiatement un médecin.

Regulatory Compliance

FCC Statements

This device complies with Part 15 of the FCC Rules. Operation is subject to the following two conditions: (1) this device may not cause harmful interference, and (2) this device must accept any interference received, including interference that may cause undesired operation.

Visit https://global.uniview.com/Support/Download_Center/Product_Installation/Declaration/ for SDoC.

Caution: The user is cautioned that changes or modifications not expressly approved by the party responsible for compliance could void the user's authority to operate the equipment.

NOTE: This equipment has been tested and found to comply with the limits for a Class A digital device, pursuant to part 15 of the FCC Rules. These limits are designed to provide reasonable protection against harmful interference when the equipment is operated in a commercial environment. This equipment generates, uses, and can radiate radio frequency energy and, if not installed and used in accordance with the instruction manual, may cause harmful interference to radio communications. Operation of this equipment in a residential area is likely to cause harmful interference in which case the user will be required to correct the interference at his own expense.

LVD/EMC Directive



This product complies with the European Low Voltage Directive 2014/35/EU and EMC Directive 2014/30/EU.

WEEE Directive—2012/19/EU



The product this manual refers to is covered by the Waste Electrical & Electronic Equipment (WEEE) Directive and must be disposed of in a responsible manner.

Battery Regulation- (EU) 2023/1542



Battery in the product complies with the European Battery Regulation (EU) 2023/1542. For proper recycling, return the battery to your supplier or to a designated collection point.