

500KG Single Door Electromagnetic Lock Z-Shaped Bracket OEA-MS12-500Z



Overview

OEA-MS12-500Z is a Z-Bracket for 280kg magnetic locks

Features

- Used to install the armature plate of 500kg magnetic locks

Specifications

Model	OEA-MS12-500Z
Physical	
Material	Aluminum alloy
Hardware Specification	
Dimensions (L x W x H)	185*60*60mm
Weight	0.72kg

Ordering Info

Product Model	Description
OEA-MS12-500Z	500KG Single Door Electromagnetic Lock Z-Shaped Bracket

Dimensions

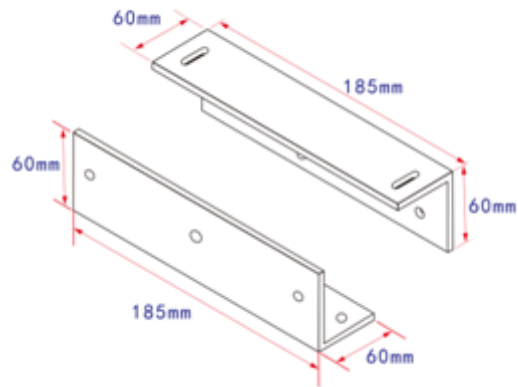

Unlimited New View

Zhejiang Uniview Technologies Co., Ltd.



<http://www.uniview.com>



overseasbusiness@uniview.com; globalsupport@uniview.com



No. 369, Xietong Road, Xixing Sub-district, Binjiang District, Hangzhou City, 310051, Zhejiang Province, China



©2023-2025 Zhejiang Uniview Technologies Co., Ltd. All rights reserved.

*Product specifications and availability are subject to change without notice.

Despite our best efforts, technical or typographical errors may exist in this document. Uniview cannot be held responsible for any such errors and reserves the right to change the contents of this document without prior notice.