

Outdoor High-performance Bridge WLN-EB5E-IN



Features

- Supports 802.11a/n standard
- The highest transmission rate is 90Mbps
- Outdoor transmission distance: 0~3km
- Integrated antenna, quick installation.
- Shipped in pairs, no configuration required
- Built-in VTrans technology, including
 - 1) TDMA: eliminate the performance degradation caused by hidden terminals and maximize the wireless transmission efficiency
 - 2) Frequency (channel) expansion function: eliminate interference caused by the same frequency and adjacent frequency through more frequency selection
 - 3) Band width selection: by adjusting the channel width, the overlapping parts of spectrum can be avoided and the influence of interference by other channels can be reduced
 - 4) AutoAck function: intelligently calculate the ACK value required for long-distance transmission to achieve the optimal performance at this distance
- Supports bridge and router modes. Network architecture can be flexibly deployed by adjusting the network mode of devices
- Intelligent QoS wireless multimedia optimization technology, providing high priority transmission levels for voice and video
- Supports web page management, making installation and maintenance of equipment more convenient
- IP65

Specifications

Model	WLN-EB5E-IN
Hardware Specification	
Dimensions(mm)	288x88x45mm
Weight(kg)	0.3kg
Installation	Pole mounting Diameter≤75mm
Protection Level	IP65
Antenna Gain	15dBi
Beam Width	H: 40°, V: 15°
Max Power Consumption(W)	8W
Average Power Consumption(W)	5W
CPU	AR9344
DDR \ Memory	64MB DDR2, 8MB Flash
Physical Interface	2*10/100Mbps
Indicator Light	1*Power Indicator 1*WLAN Indicator 1*LAN Indicator 3* Signal strength indicator
Maximum Transmitted Power	27dBm
Working Temperature	-40°C~65°C
Working Humidity	5%~95%RH Non-condensing
Surge	POE/GE: CM 1KV, DM 1KV
ESD Protection	Contact 6KV, Air 8KV
Wind Survivability	134km/h
Hardware Specification	
Power Supply	24V Passive POE
Storage Temperature	-40°C~85°C
Software Specification	
Protocol	802.11a/n
Frequency	5180~5320MHz、5745~5825MHz (China) 5180~5320MHz、5500~5720MHz、5745~5825MHz (United States) 5160~5340MHz、5480~5720MHz、5745~5865MHz (India) 5160~5340MHz、5480~5720MHz、5745~5825MHz (United Arab Emirates) 5745~5805MHz (Indonesia) Supported frequency range: 4920~6100MHz (should depend on the local regulation.) * The above frequencies need specific version support
Operating Mode	AP, Station, WDS AP, WDS Station
Network Mode	Bridge/ Router
Management	Support Web/AC/SNMP
Other	Timed restart, Support VLAN, QoS, Watchdog

Software Specification	
Security	WPA2-PSK, Hidden SSID, IP/MAC Filtering

RF Specification

Ⓢ	TX PowerⓈ			SensitivityⓈ		
	Date RateⓈ	Avg. TXⓈ	ToleranceⓈ	Date RateⓈ	SensitivityⓈ	ToleranceⓈ
11a/nⓈ	6 MbpsⓈ	24dBmⓈ	+/- 2dBmⓈ	6 MbpsⓈ	-93dBmⓈ	+/- 2dBmⓈ
	54 MbpsⓈ	21dBmⓈ	+/- 2dBmⓈ	54 MbpsⓈ	-74dBmⓈ	+/- 2dBmⓈ
	HT20 MCS0(combination)Ⓢ	27dBmⓈ	+/- 2dBmⓈ	HT20 MCS0Ⓢ	-93dBmⓈ	+/- 2dBmⓈ
	HT20 MCS7(combination)Ⓢ	23dBmⓈ	+/- 2dBmⓈ	HT20 MCS7Ⓢ	-73dBmⓈ	+/- 2dBmⓈ
	HT40 MCS0(combination)Ⓢ	27dBmⓈ	+/- 2dBmⓈ	HT40 MCS0Ⓢ	-90dBmⓈ	+/- 2dBmⓈ
	HT40 MCS7(combination)Ⓢ	23dBmⓈ	+/- 2dBmⓈ	HT40 MCS7Ⓢ	-70dBmⓈ	+/- 2dBmⓈ

Networking

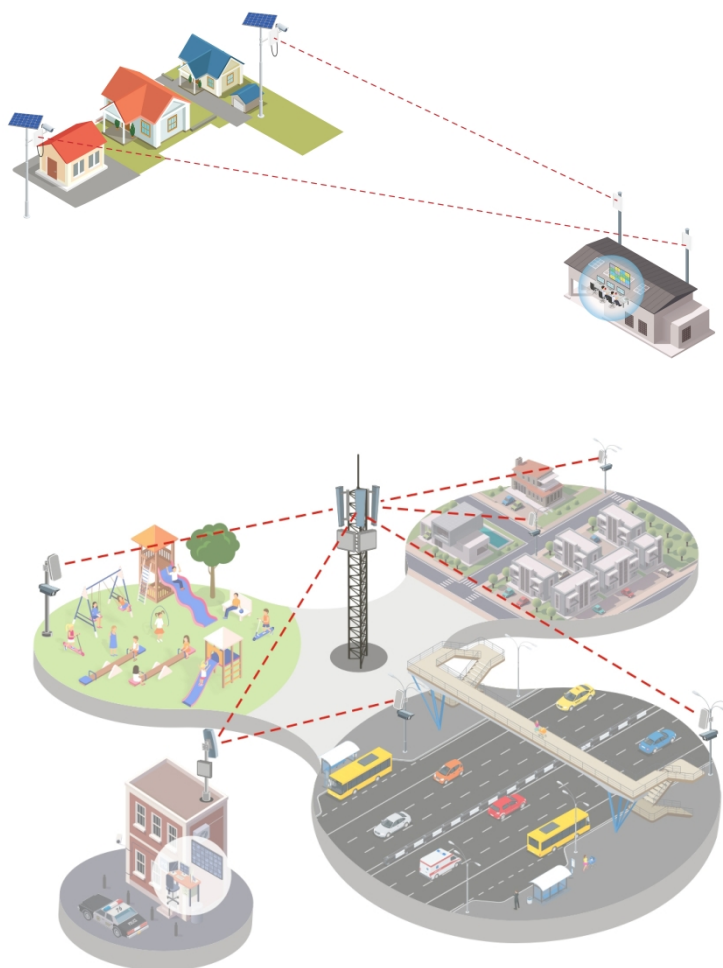

Dimensions

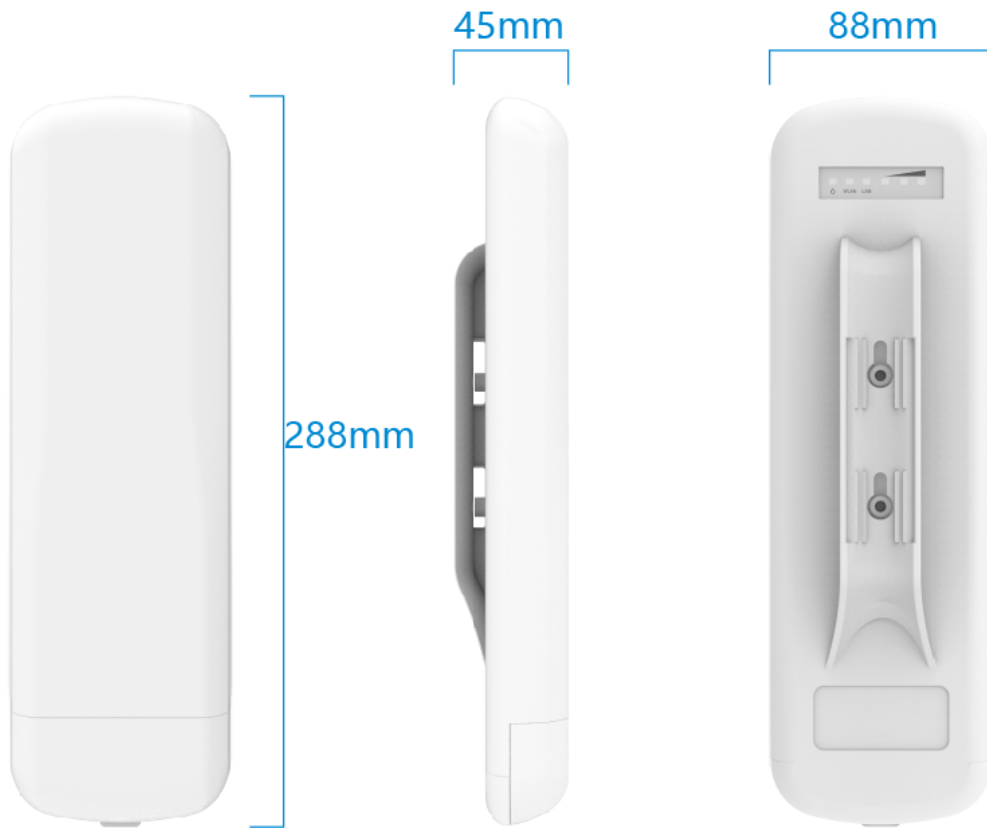

Interface

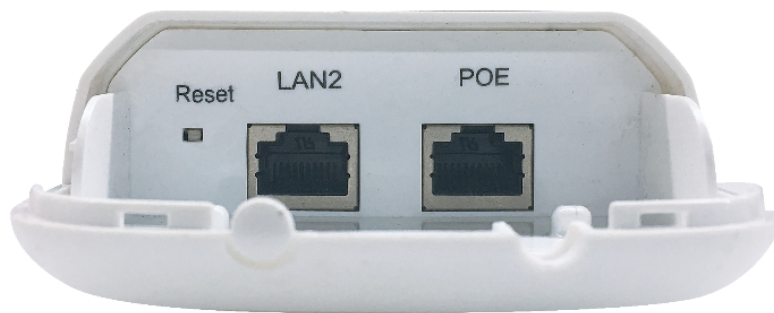

Packing List

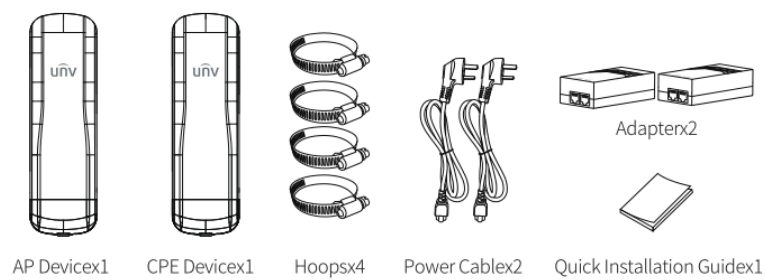

Installation

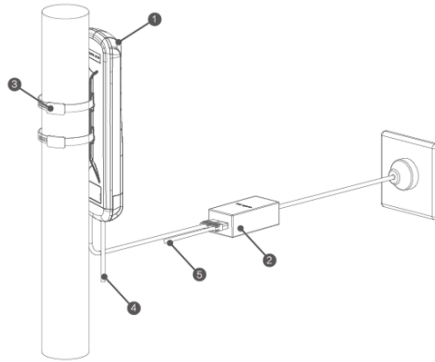

- 1. Wireless Transmission Device
 - 2. POE Adaptor
 - 3. Metal cable tie
 - 4. The LAN2 port on the main device can be connected with the other devices
 - 5. The LAN port of POE adaptor can be connected with the other devices
 - 6. The installation height needs to be more than 6 meters
- *The actual installation height needs to be determined according to the transmission distance and the installation environment, and

Antenna Polar Plots

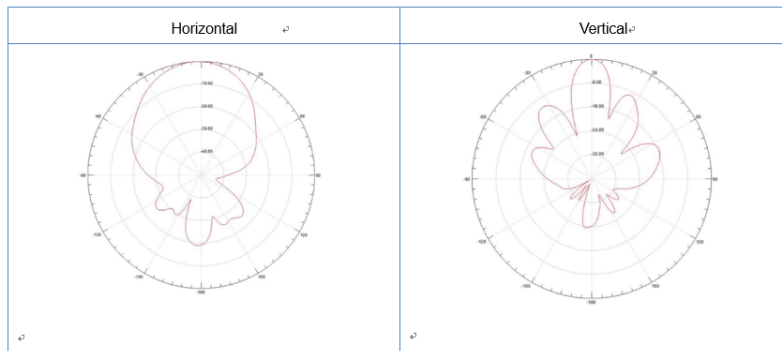

Unlimited New View

Zhejiang Uniview Technologies Co., Ltd.



<http://www.uniview.com>



overseasbusiness@uniview.com; globalsupport@uniview.com



No. 369, Xietong Road, Xixing Sub-district, Binjiang District, Hangzhou City, 310051, Zhejiang Province, China



©2023-2025 Zhejiang Uniview Technologies Co., Ltd. All rights reserved.

*Product specifications and availability are subject to change without notice.

Despite our best efforts, technical or typographical errors may exist in this document. Uniview cannot be held responsible for any such errors and reserves the right to change the contents of this document without prior notice.