

# OFG5311 Tripod Turnstile

## OFG5311

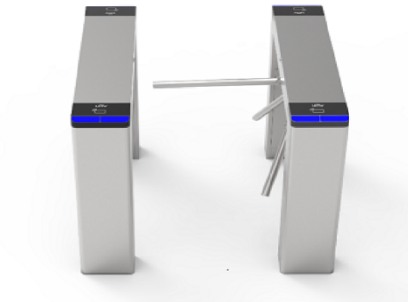

## Overview

OFG5311 tripod turnstile is designed for personnel access control. It has a simple and elegant design, and can be used not only with UNV access control devices to realize precise access control by utilizing UNV access control technologies, but also with UNV smart terminals to resolve issues plaguing traditional barrier gates such as illegal access using credentials of authorized persons. This product can be widely used in office buildings, government agencies, airports, scenic spots, stadiums, schools and other important places to achieve smart, safe and fast access control.

## Features

- Pedestrian-only access.
- All-round security design
- Automatic door opening for unobstructed access in case of power failure.
- Electric leakage protection for pedestrian safety.
- LED indicates the passing direction and passing status, preventing reverse access.
- Highly reliable hardware design
- Pedestals of 1.0mm thick on the side and 1.2mm thick on the top, sturdy and reliable, simple and elegant.
- IP54.
- Solenoid valve unlocking design provides long lifetime, high reliability, and fast door opening.
- Intelligent behavior detection and access control

- Anti-rush: Remains closed unless an opening signal is received.
- Anti-impact: Able to withstand illegal external impacts for controller protection.
- Automatic reset: Automatically cancels the passing permission if a person does not pass through within the valid passing duration.
- Powerful control center
- STC CPU chip ensures long lifetime and high stability.
- MCBF 3 million times.
- Complete application solution
- With smart terminals connected, multiple authentication modes are available, such as password and card.

## Specifications

Model	OFG5311-R-C	OFG5311-N-C
<b>Hardware Specification</b>		
Lane width	550mm	
Barrier material	Stainless steel round rod	
Dimensions (L×W×H)	1200mm*220mm*980mm	
Weight	45KG (empty pedestal: 30KG)	
Pedestal material	1.0mm thick on the side, 1.2mm thick on the top	
Power supply	AC100-240V, 50Hz to 60Hz	None
IO	IO*1	None
Indicator color	Blue	None
<b>Specification index</b>		
Throughput	20 to 30 persons per minute	
Operating environment	Operating humidity:5% to 80%; Operating humidity:20°C to +60°C (temperature control module required)	
Power consumption	40W	None
MCBF	3 million times	
Fire alarm linkage	Auto fall after power failure, manual lift after power on, auto reset after impacts	

## Ordering Info

Product Model	Description
OFG5311-N-C	Outdoor Tripod Turnstile(Empty Case)
OFG5311-R-C	Outdoor Tripod Turnstile(Right Machine)

## Accessories

OEC-R3H-M

Wall Mounted Mifare Card Reader



## Dimensions

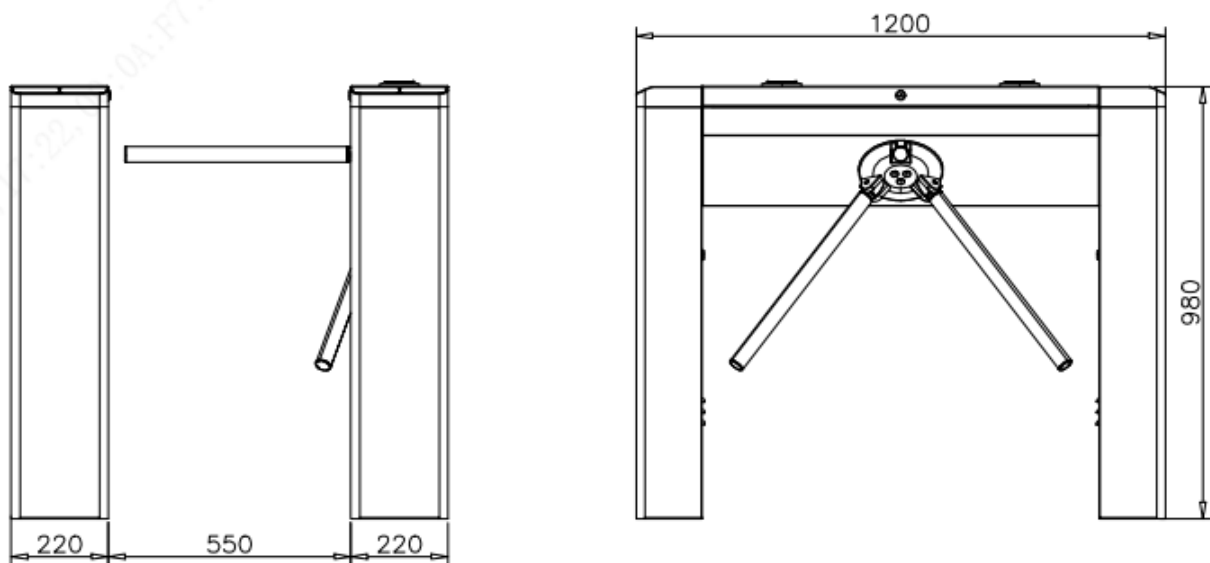

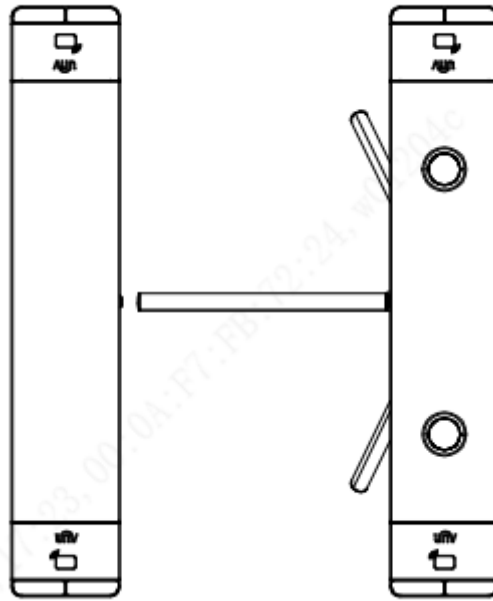

**Zhejiang Uniview Technologies Co., Ltd.**

No. 369, Xietong Road, Xixing Sub-district, Binjiang District, Hangzhou City, 310051, Zhejiang Province, China (Zhejiang) Pilot Free Trade Zone, China

Email: [overseasbusiness@uniview.com](mailto:overseasbusiness@uniview.com); [globalsupport@uniview.com](mailto:globalsupport@uniview.com)

<http://www.uniview.com>

©2024 Zhejiang Uniview Technologies Co., Ltd. All rights reserved.

\*Product specifications and availability are subject to change without notice.

\*Despite our best efforts, technical or typographical errors may exist in this document. Uniview cannot be held responsible for any such errors and reserves the right to change the contents of this document without prior notice.