

**TR-WM08-B Platform Wall Mount Bracket**  
**TR-WM08-B**



# Specifications

<b>Model</b>	<b>TR-WM08-B</b>
<b>Bracket</b>	
<b>Application</b>	Indoor/Outdoor
<b>Application Range</b>	76series/explosion-proof position system
<b>Bracket Dimensions</b>	523mm*180mm*150mm (20.6"x7.1"x5.9")
<b>Bracket Weight</b>	6.0kg(13.2lb)
<b>Bearable Load</b>	40.0kg(88.0lb)
<b>Bracket Material</b>	Stainless steel

# Dimensions

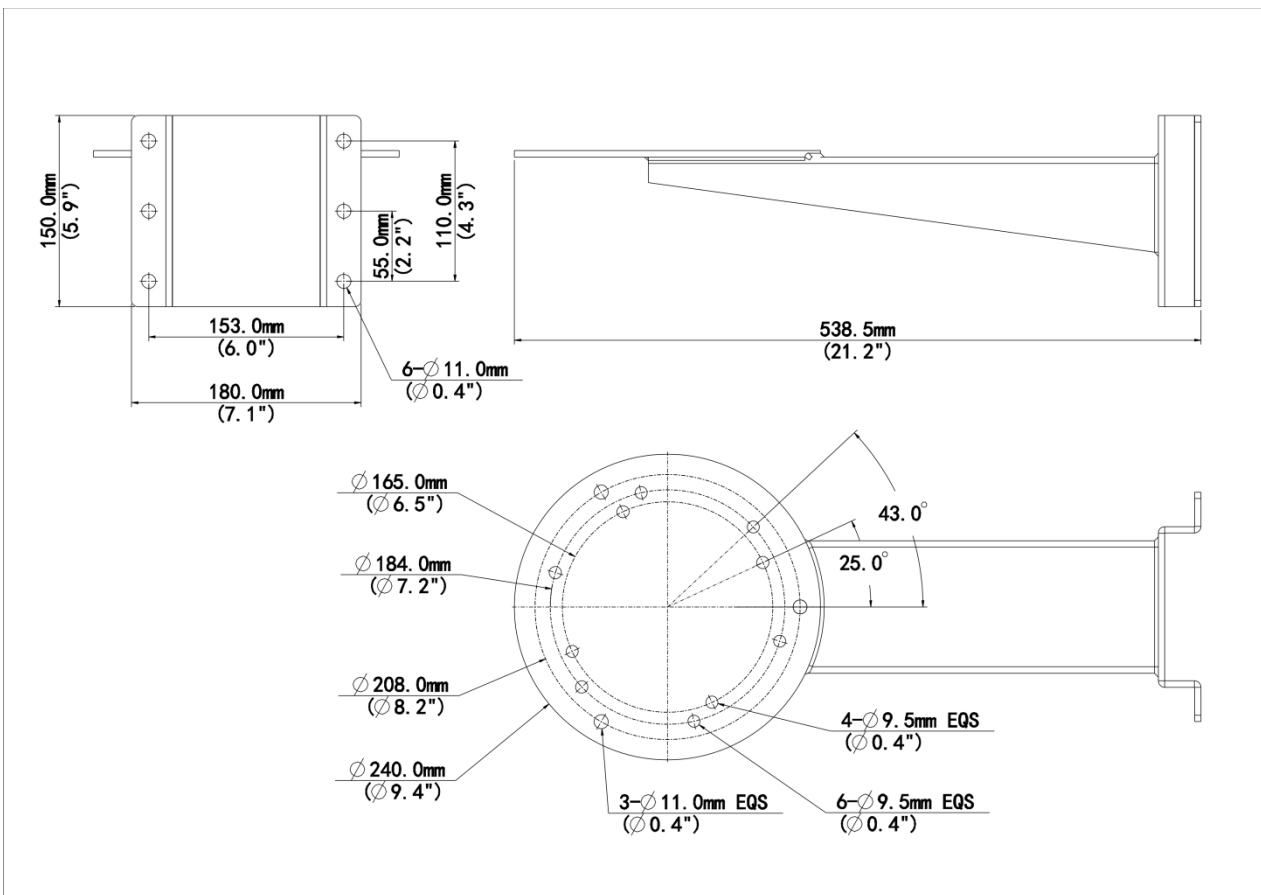

# Ordering Info

Product Model	Description
TR-WM08-B	Wall Mounting Bracket for Explosion-proof Pan-Tilt

# Unlimited New View

## Zhejiang Uniview Technologies Co., Ltd.



<http://www.uniview.com>



[overseasbusiness@uniview.com](mailto:overseasbusiness@uniview.com); [globalsupport@uniview.com](mailto:globalsupport@uniview.com)



No. 369, Xietong Road, Xixing Sub-district, Binjiang District, Hangzhou City, 310051, Zhejiang Province, China



©2023-2025 Zhejiang Uniview Technologies Co., Ltd. All rights reserved.

\*Product specifications and availability are subject to change without notice.

Despite our best efforts, technical or typographical errors may exist in this document. Uniview cannot be held responsible for any such errors and reserves the right to change the contents of this document without prior notice.