

2MP LightHunter HD IR Fixed Dome Analog Camera

UAC-D122-AF28(40)M



Overview

UAC-D122-AF28(40)M is a 2MP LightHunter HD IR fixed dome analog camera with a high-performance 1/2.9-inch CMOS sensor and 3D noise reduction technology. It supports TVI/AHD/CVI/CVBS, which effectively enhances product adaptability and diversity of networking solutions. With SYV-75-3 or other coaxial cable types, the camera can achieve low-cost, long-distance, and anti-interference mega-pixel HD video transmission without time delay. It supports IR-cut filter with auto-switch (ICR) and provides color images at daytime and black/white images at night. The camera also supports audio input and synchronous transmission of audio and video.

Features

- High quality imaging with 2MP resolution
- TVI/AHD/CVI/CVBS
- Supports IR-cut filter with auto-switch (ICR)
- LightHunter monitoring with high-sensitivity sensor
- 3D noise reduction technology delivers clean and sharp images
- Supports 180° horizontal/vertical flip

- OSD configuration menu, easy to operate
- Water and dust resistant (IP67) and vandal-resistant (IK10)
- OSD configuration menu in 11 languages
- Built-in microphone for high quality audio transmission via coaxial cables
- Supports digital defog
- Metal base and metal housing
- 3-Axis

Specifications

Model	UAC-D122-AF28M	UAC-D122-AF40M
Sensor		
Pixel	2 MP	
Sensor Size	1/2.9" CMOS	
Min. Illumination	0.005 lux (F1.6, AGC ON) 0 lux (IR on)	
Lens		
Focus	2.8 mm	4.0 mm
Lens Mount	M12	
Angle of View (H)	101.5°	83.8°
Angle of View (V)	56.9°	42.7°
Angle of View (D)	117.4°	100.1°
Illuminator		
Illuminator Number	One IR illuminator	
Illumination Distance	30m	
Lifetime	≥ 60000 hours	
Video		
Resolution	1080P: 1920(H)×1080(V) 720P: 1280(H) ×720(V)	
Frame Rate	TVI: 1080P@25fps (default), 1080P@30fps; 720P@25fps, 720P@30fps AHD: 1080P@25fps, 1080P@30fps; 720P@25fps, 720P@30fps CVI: 1080P@25fps, 1080P@30fps; 720P@25fps, 720P@30fps CVBS: PAL, NTSC	

Shutter Time	PAL: 1/25s-1/50000s, NTSC: 1/30s-1/50000s
Image	
Exposure Mode	Four modes: Global (default), BLC, HLC, DWDR
Day/Night	Three modes: Auto (default), Day, Night
Digital Noise Reduction	2D/3D
White Balance	Two modes: Auto (default), Manual
WDR	DWDR
Smart IR	Support
Flip	Supports 180°horizontal flip, 180°vertical flip
Digital Defog	Support
Audio	
Built-in Mic	Support
Camera Audio	TVI: 1080P@25fps, 1080P@30fps CVI: 1080P@25fps, 1080P@30fps
Interface	
Power Interface	5.5 mm Power Interface
Video Output	BNC, supports TVI/AHD/CVI/CVBS
Operating Environment	
Temperature	-30°C to 60°C (-22°F to 140°F)
Humidity	≤ 95% RH (non-condensing)
Surge Protection	4 KV for power, 4 KV for video output interfaces
Ingress Protection	IP67
IK Rating	IK10
General	
Power	DC 12 V ± 25%
Power Consumption	MAX 3.3W
Mount	Wall Mount, Pole Mount, Corner Mount, Tilted Mount, Pendant Mount
Dimensions	Φ109mm*83mm (diameter*height)
Material	Metal
Weight	372g(0.82lb)

Dimensions

Aggregate product size diagram using "main model" as an example

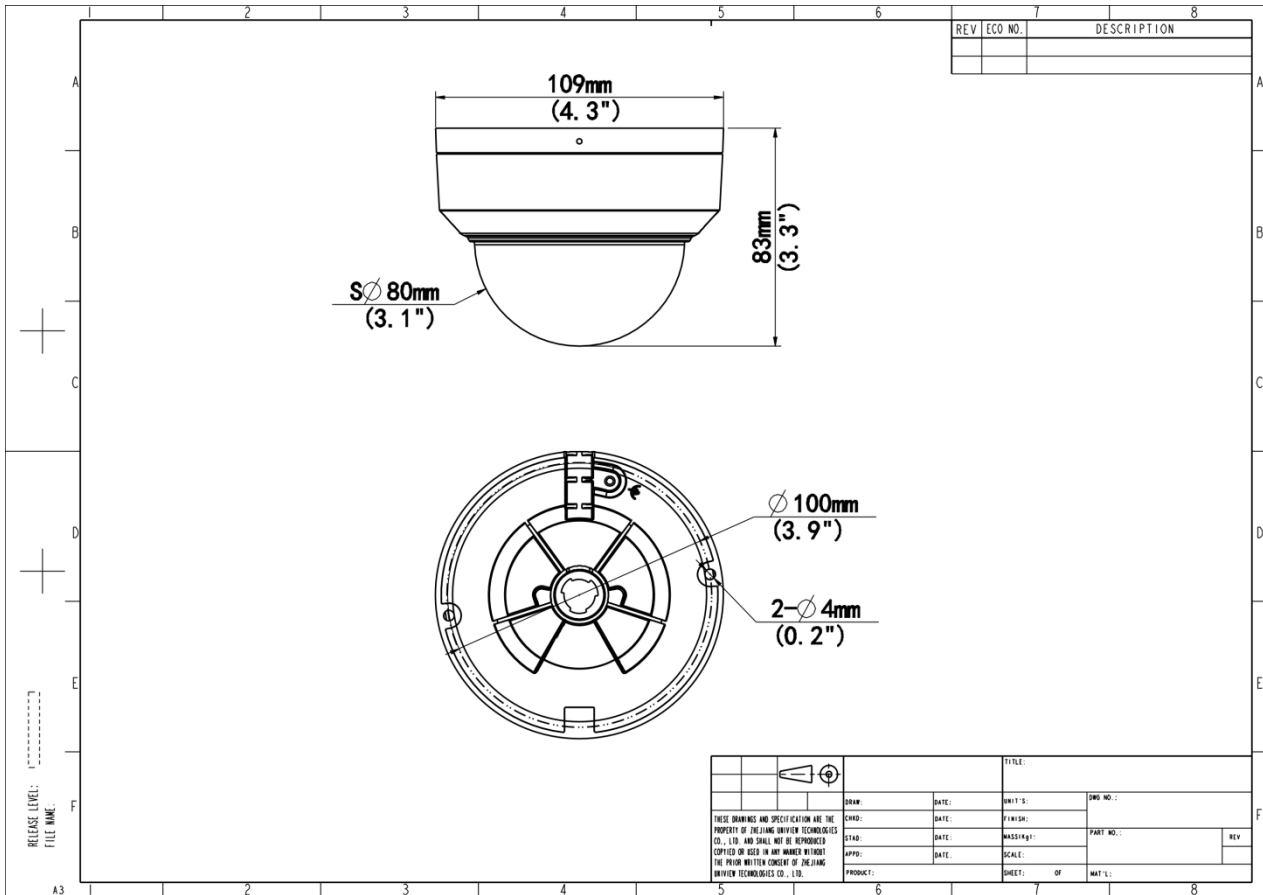

Zhejiang Uniview Technologies Co., Ltd.

No. 369, Xietong Road, Xixing Sub-district, Binjiang District, Hangzhou City, 310051, Zhejiang Province, China

Email: overseasbusiness@uniview.com; globalsupport@uniview.com

<http://www.uniview.com>

©2023-2025 Zhejiang Uniview Technologies Co., Ltd. All rights reserved.

*Product specifications and availability are subject to change without notice.

*Despite our best efforts, technical or typographical errors may exist in this document. Uniview cannot be held responsible for any such errors and reserves the right to change the contents of this document without prior notice.