

Slant Mounting Bracket for Fixed Dome

TR-UM06-E-IN

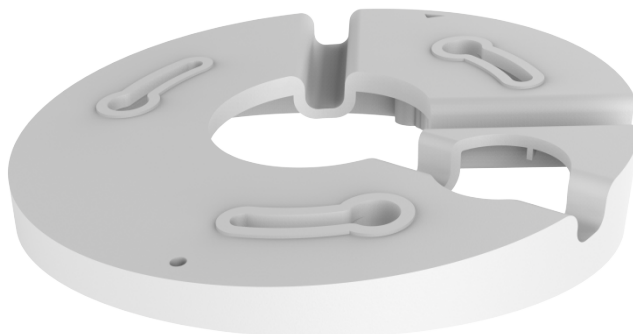

Specifications

Model	TR-UM06-E-IN
Bracket	
Application	Indoor, incline installation for IPC32XS/E/L series
Bracket Dimensions	Ø109.6*24.2mm
Bracket Weight	0.04kg(0.1lb)
Bearable Load	1.5kg(3.3lb)
Bracket Material	Plastic

Dimensions

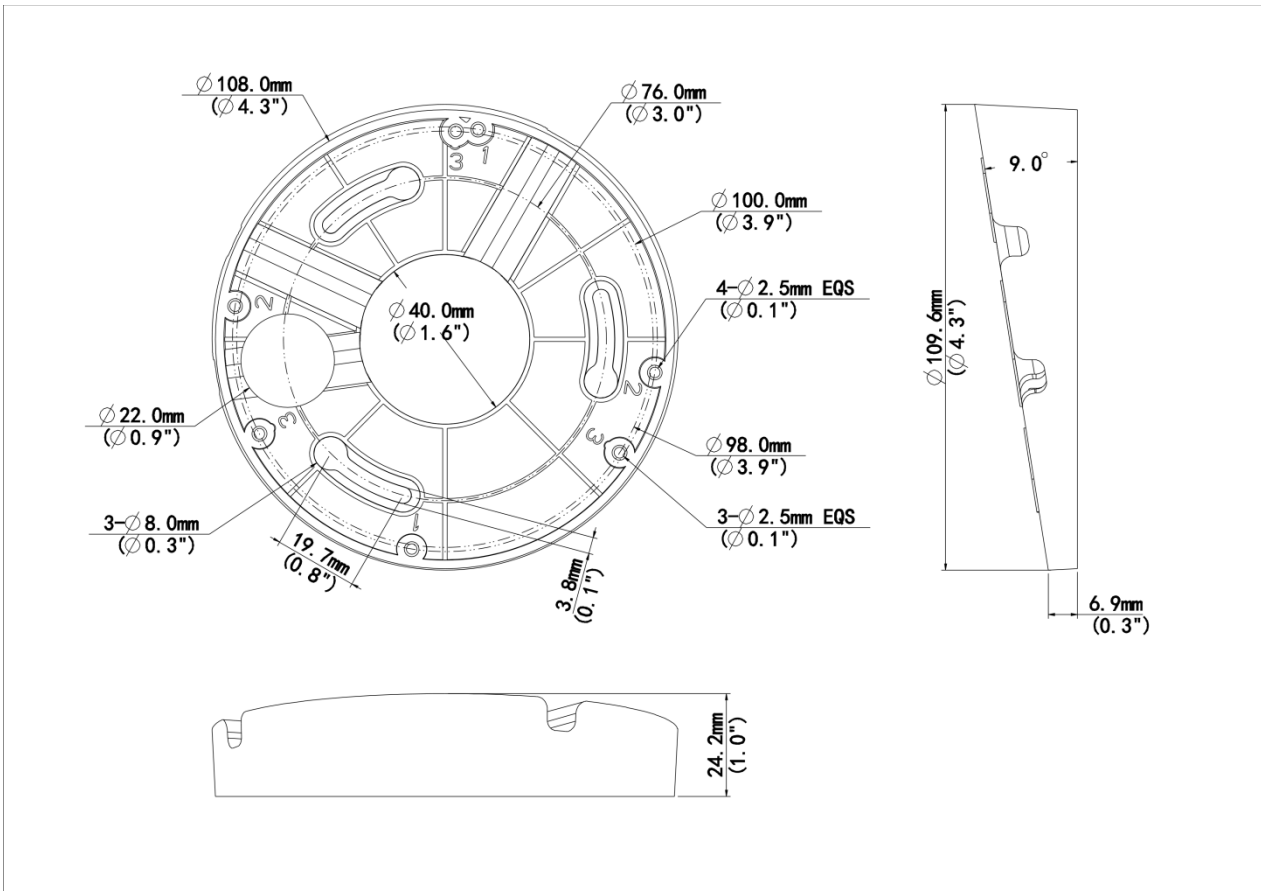

Zhejiang Uniview Technologies Co., Ltd.

No. 369, Xietong Road, Xixing Sub-district, Binjiang District, Hangzhou City, 310051, Zhejiang Province, China (Zhejiang) Pilot Free Trade Zone, China

Email: overseasbusiness@uniview.com; globalsupport@uniview.com

<http://www.uniview.com>

©2023-2024 Zhejiang Uniview Technologies Co., Ltd. All rights reserved.

*Product specifications and availability are subject to change without notice.

*Despite our best efforts, technical or typographical errors may exist in this document. Uniview cannot be held responsible for any such errors and reserves the right to change the contents of this document without prior notice.