

TR-WE45-E-IN Wall Mount Bracket  
TR-WE45-E-IN



# Specifications

<b>Model</b>	TR-WE45-E-IN
<b>Bracket</b>	
<b>Application</b>	Indoor/Outdoor
<b>Bracket Dimensions</b>	312.7mmx140.9mmx297.0mm(12.3" x 5.5"x 11.7")
<b>Bracket Weight</b>	1.4kg(3.1lb)
<b>Bracket Material</b>	Aluminum alloy
<b>Adjustable Range</b>	Vertical: -45°~ 60°
<b>Application Range</b>	Omniview Network Camera+PTZ dome

# Dimensions

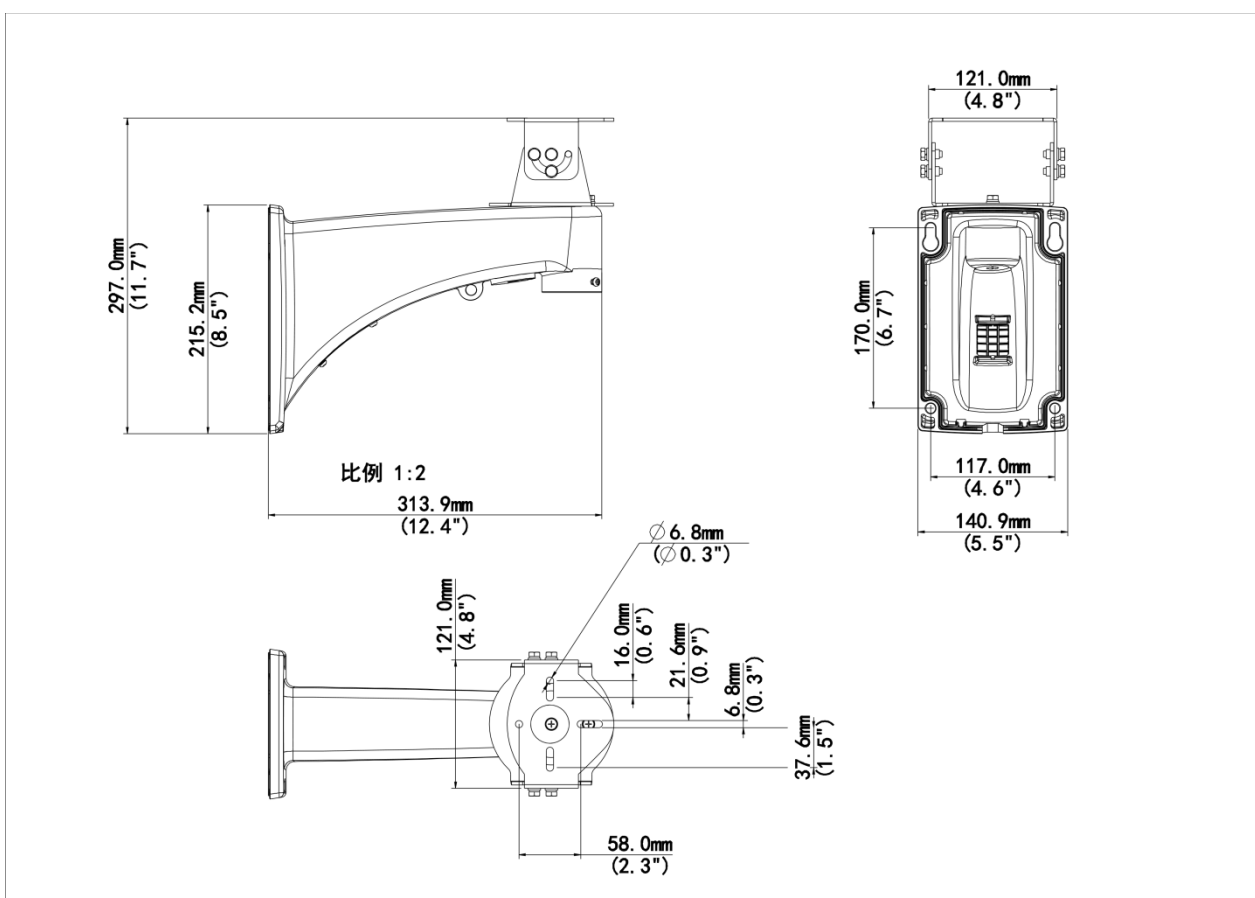

# Ordering Info

Product Model	Description
TR-WE45-E-IN	Wall Mounting Bracket for Panoramic Camera &Dome

# Unlimited New View

## Zhejiang Uniview Technologies Co., Ltd.



<http://www.uniview.com>



[overseasbusiness@uniview.com](mailto:overseasbusiness@uniview.com); [globalsupport@uniview.com](mailto:globalsupport@uniview.com)



No. 369, Xietong Road, Xixing Sub-district, Binjiang District, Hangzhou City, 310051, Zhejiang Province, China



©2023-2025 Zhejiang Uniview Technologies Co., Ltd. All rights reserved.

\*Product specifications and availability are subject to change without notice.

Despite our best efforts, technical or typographical errors may exist in this document. Uniview cannot be held responsible for any such errors and reserves the right to change the contents of this document without prior notice.