

ITS Overseas multi-lane speed radar

RD107@A-6-OS



Features

- Support two-way trigger, retrograde capture
- Support formal and side loading;
- Adopt 24GHz MMIC technology, superior performance;
- High gain and low sidelobe microstrip antenna design technology can effectively avoid adjacent channel target interference.;
- Accurate ranging and speed measurement for multiple targets, accurate positioning;
- High-precision fixed-point capture, the position error is within 1 m, and the capture rate is above 99%.;
- Strong environmental adaptability, and the detection performance is not disturbed by external environment such as light, dust, rain and snow.

Specifications

Performance	Description
Number of lanes	6
Vehicle capture rate	≥99%
Speed measurement error	≥ 100km/h (-1-0)km/h < 100km/h(-0.5-0)km/h
Trigger Consistency	≤ ±0.5m
Speed measurement range	10~300 km/h
Tracking distance	18~38m
Mounting height	4~8m

Lane width	2.75~5m adjustable
Interface Characteristics	Description
Power supply	RS485
Communication interface	DC9~12V 0.3A
General Features	Description
Weight	DC9~12V 0.3A
Antenna beam 3dB width	48°*25°
Working center frequency	24.05~24.25GHz
Power waste	≤10W
Operation temperature	-40℃~70℃
Working humidity	0-95%RH
Protection grade	IP66
Dimensions (L×W×H)	205X221X191mm

Dimensions

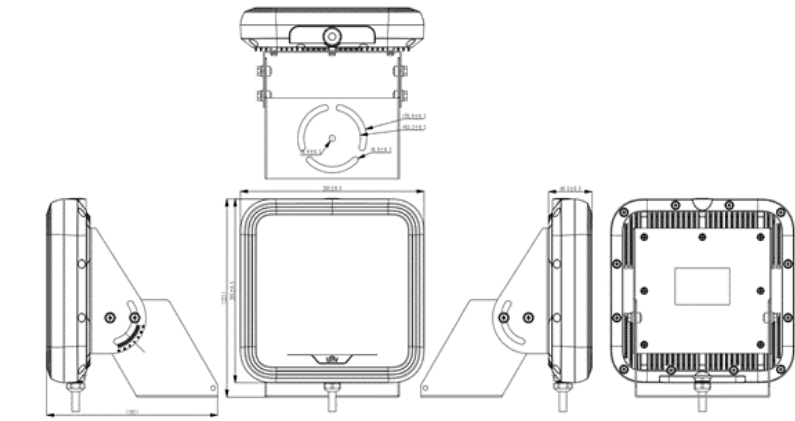

Ordering Info

Product Model	Config	Description
RD107	A-6-OS	ITS Multi-target tracking and speed measurement radar (multi-lane) , With bracket. Can be powered by the camera 12V

Zhejiang Uniview Technologies Co., Ltd.

No. 369, Xietong Road, Xixing Sub-district, Binjiang District, Hangzhou City, 310051, Zhejiang Province, China

Email: overseasbusiness@uniview.com; globalsupport@uniview.com

<http://www.uniview.com>

©2024 Zhejiang Uniview Technologies Co., Ltd. All rights reserved.

*Product specifications and availability are subject to change without notice.

*Despite our best efforts, technical or typographical errors may exist in this document. Uniview cannot be held responsible for any such errors and reserves the right to change the contents of this document without prior notice.