

**TR-UV06-C-IN Multi-sensor Panoramic Network Camera 2D Bracket
Mount**

TR-UV06-C-IN



Specifications

Model	TR-UV06-C-IN
Bracket	
Application	Indoor or outdoor, pole or rail installation
Bracket Dimensions	117 mm x 135.4 mm x 83mm (4.6" x 5.3"x 3.3")
Bracket Weight	0.28kg (0.62lb)
Bracket Material	Aluminum alloy

Dimensions

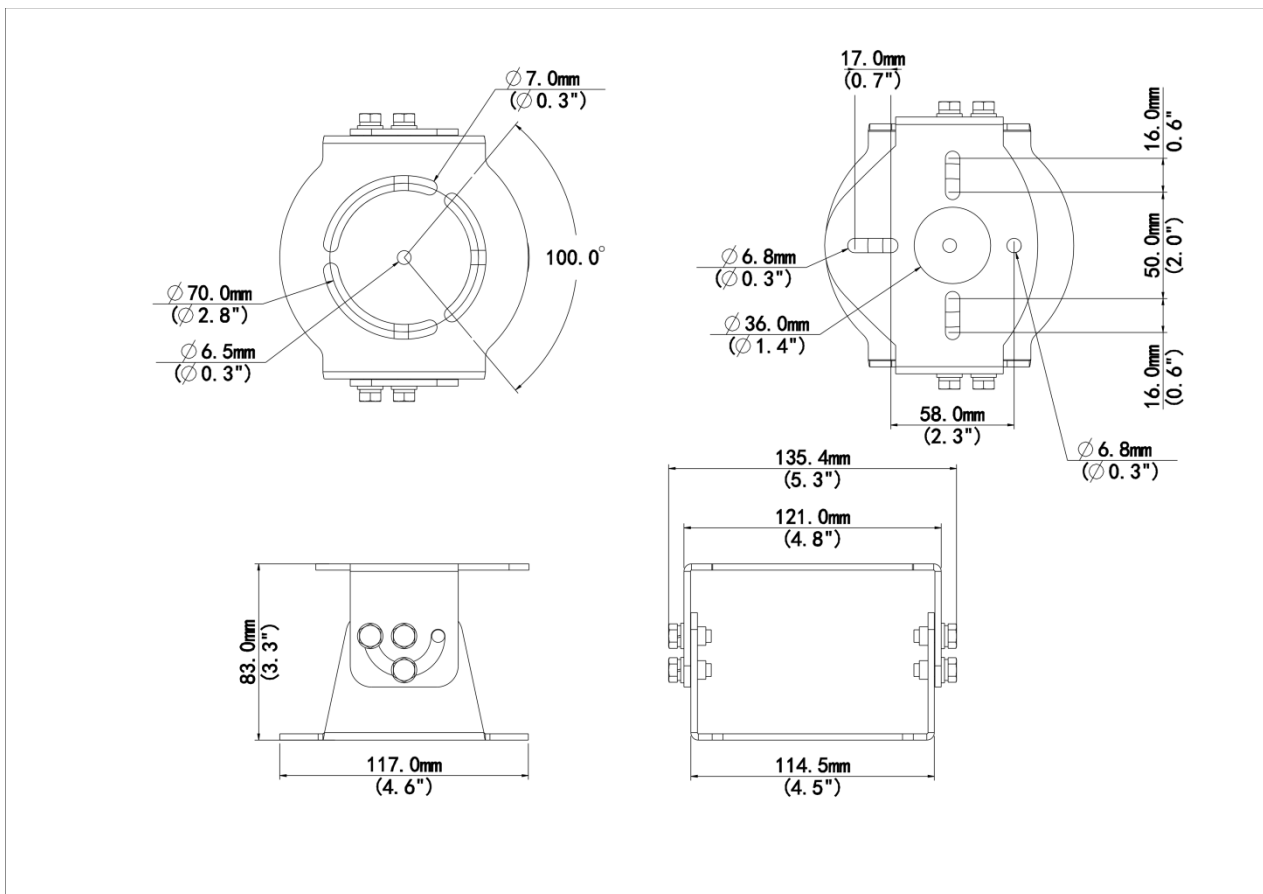

Ordering Info

Product Model	Description
TR-UV06-C-IN	Panoramic Camera 2D Mounting Bracket

Unlimited New View

Zhejiang Uniview Technologies Co., Ltd.



<http://www.uniview.com>



overseasbusiness@uniview.com; globalsupport@uniview.com



No. 369, Xietong Road, Xixing Sub-district, Binjiang District, Hangzhou City, 310051, Zhejiang Province, China



©2023-2025 Zhejiang Uniview Technologies Co., Ltd. All rights reserved.

*Product specifications and availability are subject to change without notice.

Despite our best efforts, technical or typographical errors may exist in this document. Uniview cannot be held responsible for any such errors and reserves the right to change the contents of this document without prior notice.