



# 4-Slot Desktop NAS

## Quick Guide



# 1 Packing List

The package contents may vary with device model and version.

No.	Name	Qty	Unit
1	NAS device	1	PCS
2	Pan head screw (for M.2 SSD)	3	PCS
3	Countersunk head screw (for 2.5" SATA disk)	17	PCS
4	Power adapter	1	PCS
5	Power cable	1	PCS
6	Network cable	2	PCS
7	Enclosure key	2	PCS
8	Product documents	1	Set

# 2 Appearance

The figures are only for illustrative purpose and may be different from the actual devices.

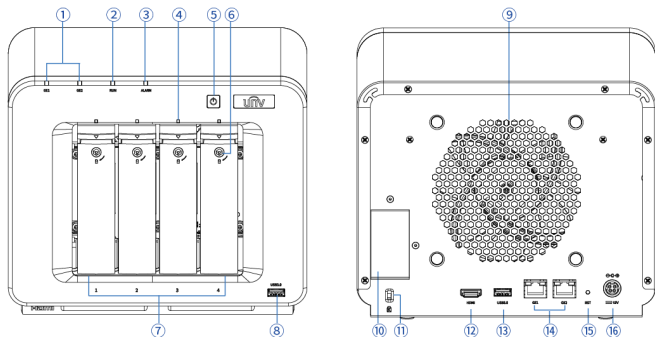

No.	Name	Description
①	Network status indicators (GE1/GE2)	<p>Indicates network connection status.</p> <ul style="list-style-type: none"> <li>● Blinking green: The device is sending/receiving data.</li> <li>● Steady green: No data sending/receiving.</li> <li>● Off: The device is turned off, or network cable is not connected.</li> </ul>
②	System status indicator (RUN)	<p>Indicates system operation status.</p> <ul style="list-style-type: none"> <li>● Blinking green: The device is starting up.</li> <li>● Steady green: The device is running normally.</li> <li>● Off: The device is turned off.</li> </ul>
③	Alarm indicator (ALARM)	<p>Indicates system alarms, such as fan fault, high temperature.</p> <ul style="list-style-type: none"> <li>● Steady red: An alarm has occurred.</li> <li>● Off: No alarm.</li> </ul>
④	Hard disk indicator	<p>Indicates the status of each hard disk.</p> <ul style="list-style-type: none"> <li>● Blinking green: The disk is reading/writing data.</li> <li>● Steady green: No data reading/writing.</li> <li>● Steady yellow: An exception has occurred.</li> <li>● Off: The device is turned off, or no hard disk is inserted.</li> </ul>
⑤	Power button	<ul style="list-style-type: none"> <li>● A quick press turns on/off the device.</li> <li>● Press and hold for at least 5s to turn off the device by force.</li> </ul> <p>The button is integrated with an indicator, which is lit when the device is operating, and is off when the device is turned off.</p>
⑥	Enclosure key hole	Used to lock/unlock the enclosure using the supplied key.
⑦	Hard disk slot	4 slots for 3.5" or 2.5" SATA disks (HDD or SSD).
⑧	Front USB3.0	Connects a USB device (such as hard disk, flash drive).

No.	Name	Description
⑨	Fan	Used for heat dissipation.
⑩	PCIe expansion slot	Used to install a PCIe card, for example, 10GE NIC.
⑪	Kensington lock slot	Allows the device to be physically secured.
⑫	HDMI	Connects a high definition display device.
⑬	Rear USB3.0	Connects a USB device (such as hard disk, flash drive).
⑭	Network interface	2 x RJ45, 10M/100M/1000M auto-adaptation.
⑮	Reset button	Press and hold for at least 5 seconds to restore the default IP address (192.168.0.1), nas user's default password (nas) and default permissions.
⑯	DC 12V input	Connects an AC power input via the power adapter for power supply.

## 3 Device Installation

### 3.1 Preparation

- Purchase the following accessories as needed.

Name	Description
2.5" or 3.5" SATA disks (HDD or SSD)	Max 4 disks. <b>Note:</b> If you plan to create RAID, it is recommended to choose disks of the same capacity to maximize space usage.
M.2 NVMe 2280 SSD	Max 2 disks.
DDR4 SODIMM memory	Max 2 memories. <b>Note:</b> One memory is supplied. You may add one more or replace the current one for expansion. Up to 32GB is allowed.

Name	Description
PCIe card (such as 10GE NIC)	Only one is allowed. <b>Note:</b> Please use a low-profile PCIe card.

- A cross screwdriver will be needed during the installation.

## 3.2 Install SATA Disk



### NOTE!

Please skip step 1 and 5 if your device does not have an air filter.

1. Open and remove the air filter.

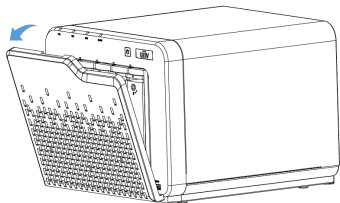

2. Open the handle from the top, drag out the disk enclosure horizontally.

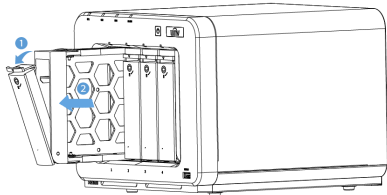

### CAUTION!

If the enclosure is locked, use the supplied key to unlock it first and then open the handle.

3. Install hard disks in the enclosure.

➤ 3.5" disk

① Remove the fastening plates on both sides of the enclosure.

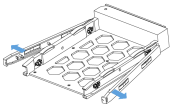

② Place the disk in the enclosure.

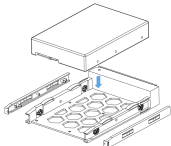

③ Insert the fastening plates, fix the hard disk.

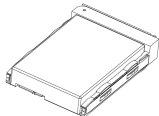

➤ 2.5" disk

① Remove a fastening plate and place it in a safe place.

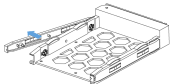

② Place the hard disk into the enclosure as shown below.

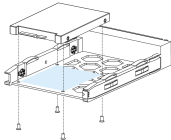

③ Flip the enclosure, tighten the 4 screws to fix the hard disk.

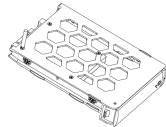

4. Insert the enclosure into the slot and then push gently till it clicks into position, and then close the handle.

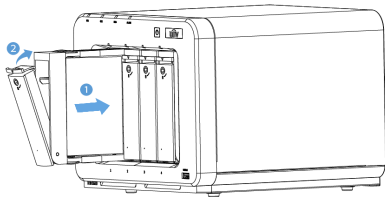

**CAUTION!**

- Be sure to insert all four enclosures (including the empty ones); otherwise, it will cause loud noise and lead to uneven heat dissipation which may cause device damage.
- After inserting the enclosures, it is recommended to lock them using the supplied key to prevent illegal physical access.

5. Install the air filter to protect the slots from dust.

### 3.3 Install M.2 SSD or Memory

**CAUTION!**

Be sure disconnect the device from power before installing or replacing the SSD or memory.

1. Loosen the 2 screws at the bottom, remove the cover.

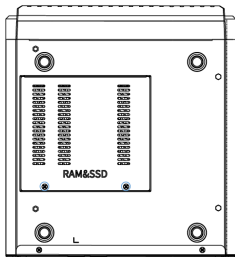

2. Install M.2 SSD or memory.

➤ Install M.2 SSD

① Align the notch on the SSD with the notch in the slot, insert the SSD.

② Check that the SSD is in position, insert the screw and then fasten.

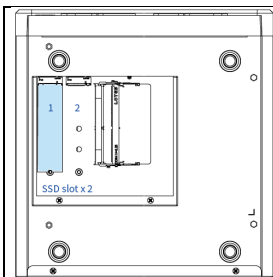

**Note:** Slot1 only for PCIe SSD, Slot2 for PCIe/SATA SSD.

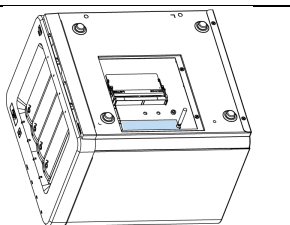

➤ Install memory

① Align the notch on the memory with the notch in the slot, insert the memory.

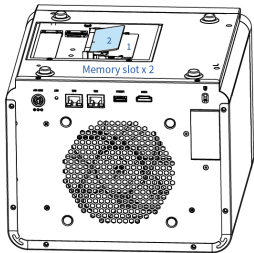

② Check that the memory is in position and is fastened in the slot.

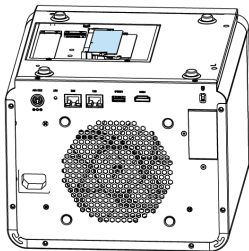

3. Install the protective cover, fasten the 2 screws.



## 3.4 Install the PCIe Card



### CAUTION!

Be sure disconnect the device from power before installing or replacing the PCIe card.

1. Loosen the 6 screws fastening the cover on the back panel, remove the cover.

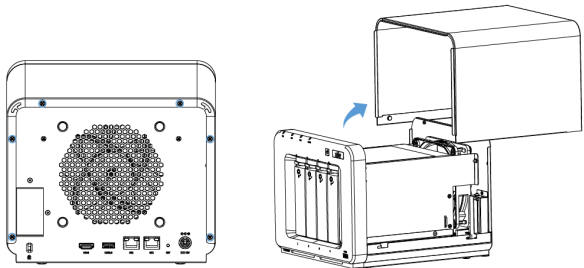

2. Loosen the screw on the PCIe filler panel, remove the filler panel.

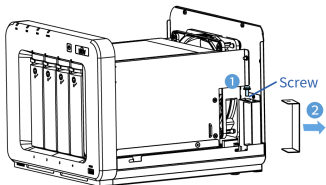

3. Insert the PCIe card into the slot, insert the screw and fasten.

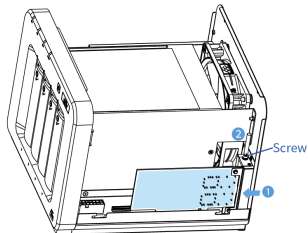

4. Install the outer cover, tighten the 6 screws.

## 4 Startup

1. Connect power.

Connect the power adapter to the power input interface on the device. Connect one end of the power cable to the power adapter, and connect the other end of the power cable to AC power socket.

2. Startup.

After power is connected, press the power button on the device. The power button is lit, which means the device is turned on.

The RUN indicator blinks when the device is starting up, and is steady on when the device is started.



### NOTE!

To turn off the device, press the power button once.

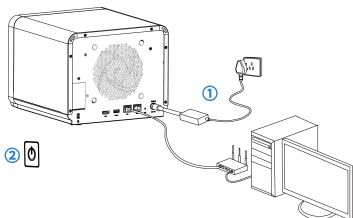

## 5 Initial Configuration

You can use SSH tools to access the NAS operating system and install software as needed.

Default network settings:

GE1 network interface	192.168.0.1
GE2 network interface	IP address is assigned via DHCP
Username/password	nas / nas

### The system startup takes a long time.

- **Symptom:** The startup takes more than 2 minutes (after you press the power button till the startup complete).
- **Possible Cause:** The disk in slot 1 functions as the startup disk of the operating system. If this disk encounters an exception, it will cause a prolonged startup time.
- **Solution:** After the device is started, access the NAS management system and check disk status at Storage Management > HDD. Replace the disk if necessary.



### NOTE!

If you need to install an operating system, be sure to install it in the disk in slot 1 or in the M.2 SSD. Other disks do not support installation of an operating system.

## Disclaimer and Safety Warnings

### Copyright Statement

©2023 Zhejiang Uniview Technologies Co., Ltd. All rights reserved.

No part of this manual may be copied, reproduced, translated or distributed in any form or by any means without prior consent in writing from Zhejiang Uniview Technologies Co., Ltd (referred to as Uniview or us hereafter).

The product described in this manual may contain proprietary software owned by Uniview and its possible licensors. Unless permitted by Uniview and its licensors, no one is allowed to copy, distribute, modify, abstract, decompile, disassemble, decrypt, reverse engineer, rent, transfer, or sublicense the software in any form by any means.

### Trademark Acknowledgements

 are trademarks or registered trademarks of Uniview.

™

The terms HDMI, HDMI High-Definition Multimedia Interface, HDMI trade dress and the HDMI Logos are trademarks or registered trademarks of HDMI Licensing Administrator, Inc.

All other trademarks, products, services and companies in this manual or the product described in this manual are the property of their respective owners.

### Export Compliance Statement

Uniview complies with applicable export control laws and regulations worldwide, including that of the People's Republic of China and the United States, and abides by relevant regulations relating to the export, re-export and transfer of hardware, software and technology. Regarding

the product described in this manual, Uniview asks you to fully understand and strictly abide by the applicable export laws and regulations worldwide.

## EU Authorised Representative

UNV Technology EUROPE B.V. Room 2945, 3rd Floor, Randstad 21-05 G, 1314 BD, Almere, Netherlands.

## Privacy Protection Reminder

Uniview complies with appropriate privacy protection laws and is committed to protecting user privacy. You may want to read our full privacy policy at our website and get to know the ways we process your personal information. Please be aware, using the product described in this manual may involve the collection of personal information such as face, fingerprint, license plate number, email, phone number, GPS. Please abide by your local laws and regulations while using the product.

## About This Manual

- This manual is intended for multiple product models, and the photos, illustrations, descriptions, etc., in this manual may be different from the actual appearances, functions, features, etc., of the product.
- This manual is intended for multiple software versions, and the illustrations and descriptions in this manual may be different from the actual GUI and functions of the software.
- Despite our best efforts, technical or typographical errors may exist in this manual. Uniview cannot be held responsible for any such errors and reserves the right to change the manual without prior notice.
- Users are fully responsible for the damages and losses that arise due to improper operation.
- Uniview reserves the right to change any information in this manual without any prior notice or indication. Due to such reasons as product version upgrade or regulatory requirement of relevant regions, this manual will be periodically updated.

## Disclaimer of Liability

- To the extent allowed by applicable law, in no event will Uniview be liable for any special, incidental, indirect, consequential damages, nor for any loss of profits, data, and documents.
- The product described in this manual is provided on an "as is" basis. Unless required by applicable law, this manual is only for informational purpose, and all statements, information, and recommendations in this manual are presented without warranty of any kind, expressed or implied, including, but not limited to, merchantability, satisfaction with quality, fitness for a particular purpose, and noninfringement.
- Users must assume total responsibility and all risks for connecting the product to the Internet, including, but not limited to, network attack, hacking, and virus. Uniview strongly recommends that users take all necessary measures to enhance the protection of network, device, data and personal information. Uniview disclaims any liability related thereto but will readily provide necessary security related support.
- To the extent not prohibited by applicable law, in no event will Uniview and its employees, licensors, subsidiary, affiliates be liable for results arising out of using or inability to use the

product or service, including, not limited to, loss of profits and any other commercial damages or losses, loss of data, procurement of substitute goods or services; property damage, personal injury, business interruption, loss of business information, or any special, direct, indirect, incidental, consequential, pecuniary, coverage, exemplary, subsidiary losses, however caused and on any theory of liability, whether in contract, strict liability or tort (including negligence or otherwise) in any way out of the use of the product, even if Uniview has been advised of the possibility of such damages (other than as may be required by applicable law in cases involving personal injury, incidental or subsidiary damage).

- To the extent allowed by applicable law, in no event shall Uniview's total liability to you for all damages for the product described in this manual (other than as may be required by applicable law in cases involving personal injury) exceed the amount of money that you have paid for the product.

## Network Security

**Please take all necessary measures to enhance network security for your device.**

The following are necessary measures for the network security of your device:

- **Change default password and set strong password:** You are strongly recommended to change the default password after your first login and set a strong password of at least nine characters including all three elements: digits, letters and special characters.
- **Keep firmware up to date:** It is recommended that your device is always upgraded to the latest version for the latest functions and better security. Visit Uniview's official website or contact your local dealer for the latest firmware.

**The following are recommendations for enhancing network security of your device:**

- **Change password regularly:** Change your device password on a regular basis and keep the password safe. Make sure only the authorized user can log in to the device.
- **Enable HTTPS/SSL:** Use SSL certificate to encrypt HTTP communications and ensure data security.
- **Enable IP address filtering:** Allow access only from the specified IP addresses.
- **Minimum port mapping:** Configure your router or firewall to open a minimum set of ports to the WAN and keep only the necessary port mappings. Never set the device as the DMZ host or configure a full cone NAT.
- **Disable the automatic login and save password features:** If multiple users have access to your computer, it is recommended that you disable these features to prevent unauthorized access.
- **Choose username and password discretely:** Avoid using the username and password of your social media, bank, email account, etc, as the username and password of your device, in case your social media, bank and email account information is leaked.
- **Restrict user permissions:** If more than one user needs access to your system, make sure each user is granted only the necessary permissions.
- **Disable UPnP:** When UPnP is enabled, the router will automatically map internal ports, and the system will automatically forward port data, which results in the risks of data leakage. Therefore, it is recommended to disable UPnP if HTTP and TCP port mapping have been enabled manually on your router.
- **SNMP:** Disable SNMP if you do not use it. If you do use it, then SNMPv3 is recommended.

- **Multicast:** Multicast is intended to transmit video to multiple devices. If you do not use this function, it is recommended you disable multicast on your network.
- **Check logs:** Check your device logs regularly to detect unauthorized access or abnormal operations.
- **Physical protection:** Keep the device in a locked room or cabinet to prevent unauthorized physical access.
- **Isolate video surveillance network:** Isolating your video surveillance network with other service networks helps prevent unauthorized access to devices in your security system from other service networks.

#### Learn More

You may also obtain security information under Security Response Center at Uniview's official website.

## Safety Warnings

The device must be installed, serviced and maintained by a trained professional with necessary safety knowledge and skills. Before you start using the device, please read through this guide carefully and make sure all applicable requirements are met to avoid danger and loss of property.

#### Storage, Transportation, and Use

- Store or use the device in a proper environment that meets environmental requirements, including and not limited to, temperature, humidity, dust, corrosive gases, electromagnetic radiation, etc.
- Make sure the device is securely installed or placed on a flat surface to prevent falling.
- Unless otherwise specified, do not stack devices.
- Ensure good ventilation in the operating environment. Do not cover the vents on the device. Allow adequate space for ventilation.
- Protect the device from liquid of any kind.
- Make sure the power supply provides a stable voltage that meets the power requirements of the device. Make sure the power supply's output power exceeds the total maximum power of all the connected devices.
- Verify that the device is properly installed before connecting it to power.
- Do not remove the seal from the device body without consulting Uniview first. Do not attempt to service the product yourself. Contact a trained professional for maintenance.
- Always disconnect the device from power before attempting to move the device.
- Take proper waterproof measures in accordance with requirements before using the device outdoors.

#### Power Requirements

- Install and use the device in strict accordance with your local electrical safety regulations.
- Use a UL certified power supply that meets LPS requirements if an adapter is used.
- Use the recommended cordset (power cord) in accordance with the specified ratings.
- Only use the power adapter supplied with your device.
- Use a mains socket outlet with a protective earthing (grounding) connection.
- Ground your device properly if the device is intended to be grounded.

#### Battery Use Caution

- When battery is used, avoid:

- Extremely high or low temperature and air pressure during use, storage and transportation.
- Battery replacement.
- Use the battery properly. Improper use of the battery such as the following may cause risks of fire, explosion or leakage of flammable liquid or gas.
  - Replace battery with an incorrect type.
  - Dispose of a battery into fire or a hot oven, or mechanically crushing or cutting of a battery.
- Dispose of the used battery according to your local regulations or the battery manufacturer's instructions.

#### **Avertissement de l'utilisation de la batterie**

- Lorsque utiliser la batterie, évitez:
  - Température et pression d'air extrêmement élevées ou basses pendant l'utilisation, le stockage et le transport.
  - Remplacement de la batterie.
- Utilisez la batterie correctement. Mauvaise utilisation de la batterie comme celles mentionnées ici, peut entraîner des risques d'incendie, d'explosion ou de fuite liquide de gaz inflammables.
  - Remplacer la batterie par un type incorrect.
  - Disposer d'une batterie dans le feu ou un four chaud, écraser mécaniquement ou couper la batterie.
- Disposer la batterie utilisée conformément à vos règlements locaux ou aux instructions du fabricant de la batterie.
- **Personal safety warnings:**
  - Chemical Burn Hazard. This product contains a coin cell battery. Do NOT ingest the battery. It can cause severe internal burns and lead to death.
  - Keep new and used batteries away from children.
  - If the battery compartment does not close securely, stop using the product and keep it away from children.
  - If you think batteries might have been swallowed or placed inside any part of the body, seek immediate medical attention.
- **Avertissements de sécurité personnelle:**
  - Risque de brûlure chimique. Ce produit contient une batterie de cellules. N'ingérer pas la batterie. Si la batterie de cellule est avalée, elle peut causer de graves brûlures internes en seulement 2 heures et peut entraîner la mort.
  - Gardez les batteries nouvelles ou utilisées à l'écart des enfants.
  - Si le compartiment de la batterie ne se ferme pas en toute sécurité, cessez d'utiliser le produit et gardez-le à l'écart des enfants.
  - Si vous pensez que des piles ont pu être avalées ou placées à l'intérieur d'une partie du corps, consultez immédiatement un médecin.

## **Regulatory Compliance**

### **FCC Statements**

This device complies with Part 15 of the FCC Rules. Operation is subject to the following two conditions: (1) this device may not cause harmful interference, and (2) this device must accept any interference received, including interference that may cause undesired operation.

Visit [http://en.uniview.com/Support/Download\\_Center/Product\\_Installation/Declaration/](http://en.uniview.com/Support/Download_Center/Product_Installation/Declaration/) for SDoC.

**Caution:** The user is cautioned that changes or modifications not expressly approved by the party responsible for compliance could void the user's authority to operate the equipment.

**NOTE:** This equipment has been tested and found to comply with the limits for a Class A digital device, pursuant to part 15 of the FCC Rules. These limits are designed to provide reasonable protection against harmful interference when the equipment is operated in a commercial environment. This equipment generates, uses, and can radiate radio frequency energy and, if not installed and used in accordance with the instruction manual, may cause harmful interference to radio communications. Operation of this equipment in a residential area is likely to cause harmful interference in which case the user will be required to correct the interference at his own expense.

#### LVD/EMC Directive



This product complies with the European Low Voltage Directive 2014/35/EU and EMC Directive 2014/30/EU.

#### WEEE Directive-2012/19/EU



The product this manual refers to is covered by the Waste Electrical & Electronic Equipment (WEEE) Directive and must be disposed of in a responsible manner.

#### Battery Directive-2013/56/EU



Battery in the product complies with the European Battery Directive 2013/56/EU. For proper recycling, return the battery to your supplier or to a designated collection point.