

OFG5312 Tripod Turnstile

OFG5312



Overview

OFG5312 tripod turnstile is designed for personnel access control. It has a simple and elegant design, and can be used not only with UNV access control devices to realize precise access control by utilizing UNV access control technologies, but also with UNV smart terminals to resolve issues plaguing traditional barrier gates such as illegal access using credentials of authorized persons. This product can be widely used in office buildings, government agencies, airports, scenic spots, stadiums, schools and other important places to achieve smart, safe and fast access control.

Features

- Pedestrian-only access.
- All-round security design
- Automatic door opening for unobstructed access in case of power failure.
- Electric leakage protection for pedestrian safety.
- LED indicates the passing direction and passing status, preventing reverse access.
- Highly reliable hardware design
- Pedestals of 1.0mm thick on the side and 1.2mm thick on the top, sturdy and reliable, simple and elegant.
- IP54.
- Solenoid valve unlocking design provides long lifetime, high reliability, and fast door opening.
- Intelligent behavior detection and access control
- Anti-rush: Remains closed unless an opening signal is received.
- Anti-impact: Able to withstand illegal external impacts for controller protection.

- Automatic reset: Automatically cancels the passing permission if a person does not pass through within the valid passing duration.
- Powerful control center
- STC CPU chip ensures long lifetime and high stability.
- MCBF 3 million times.
- Complete application solution
- With smart terminals connected, multiple authentication modes are available, such as password and card.
- Statistical function of passing records
- Supports counting the number of people through switching values.

Specifications

Hardware Specification	Description
Lane width	550mm
Barrier material	Stainless steel round rod
Dimensions (L×W×H)	980mm*430mm*320mm
Weight	35KG
Pedestal material	1.0mm thick on the side, 1.2mm thick on the top
Power supply	AC100-240V, 50Hz to 60Hz
Interface	IO input*2、 IO output *2 、 RS232*1
Indicator color	Red/Green
Specification index	Description
Throughput	20 to 30 persons per minute
Operating environment	Operating humidity:5% to 80%; Operating humidity:20°C to +60°C (temperature control module required)
Power consumption	40W
MCBF	3 million times
Fire alarm linkage	Auto fall after power failure, manual lift after power on, auto reset after impacts

Ordering Info

Product Model	Description
OFG5312-R-C	Outdoor Vertical Tripod Turnstile

Dimensions

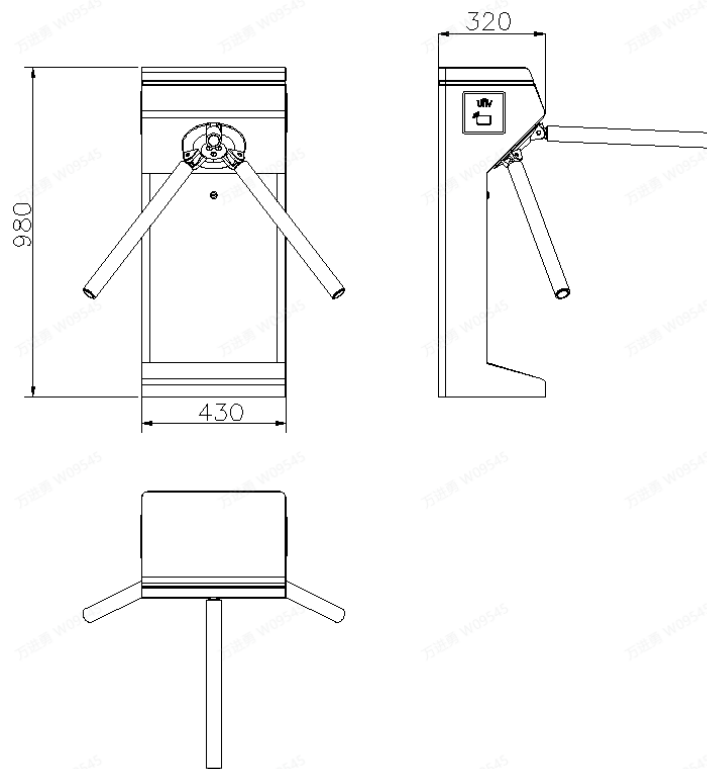

Zhejiang Uniview Technologies Co., Ltd.

No. 369, Xietong Road, Xixing Sub-district, Binjiang District, Hangzhou City, 310051, Zhejiang Province, China

Email: overseasbusiness@uniview.com; globalsupport@uniview.com

<http://www.uniview.com>

©2024 Zhejiang Uniview Technologies Co., Ltd. All rights reserved.

*Product specifications and availability are subject to change without notice.

*Despite our best efforts, technical or typographical errors may exist in this document. Uniview cannot be held responsible for any such errors and reserves the right to change the contents of this document without prior notice.