

Fixed Dome Indoor Pendant Mount

TR-CM24-IN



Specifications

Model	TR-CM24-IN
Bracket	
Application	Pendant mount for IPC323X Series fixed dome
Bracket Dimensions	Φ110mm*223.5mm (4.33" x8.80")
Bracket Weight	0.25kg(0.55lb)
Bracket Material	Aluminum alloy

Dimensions

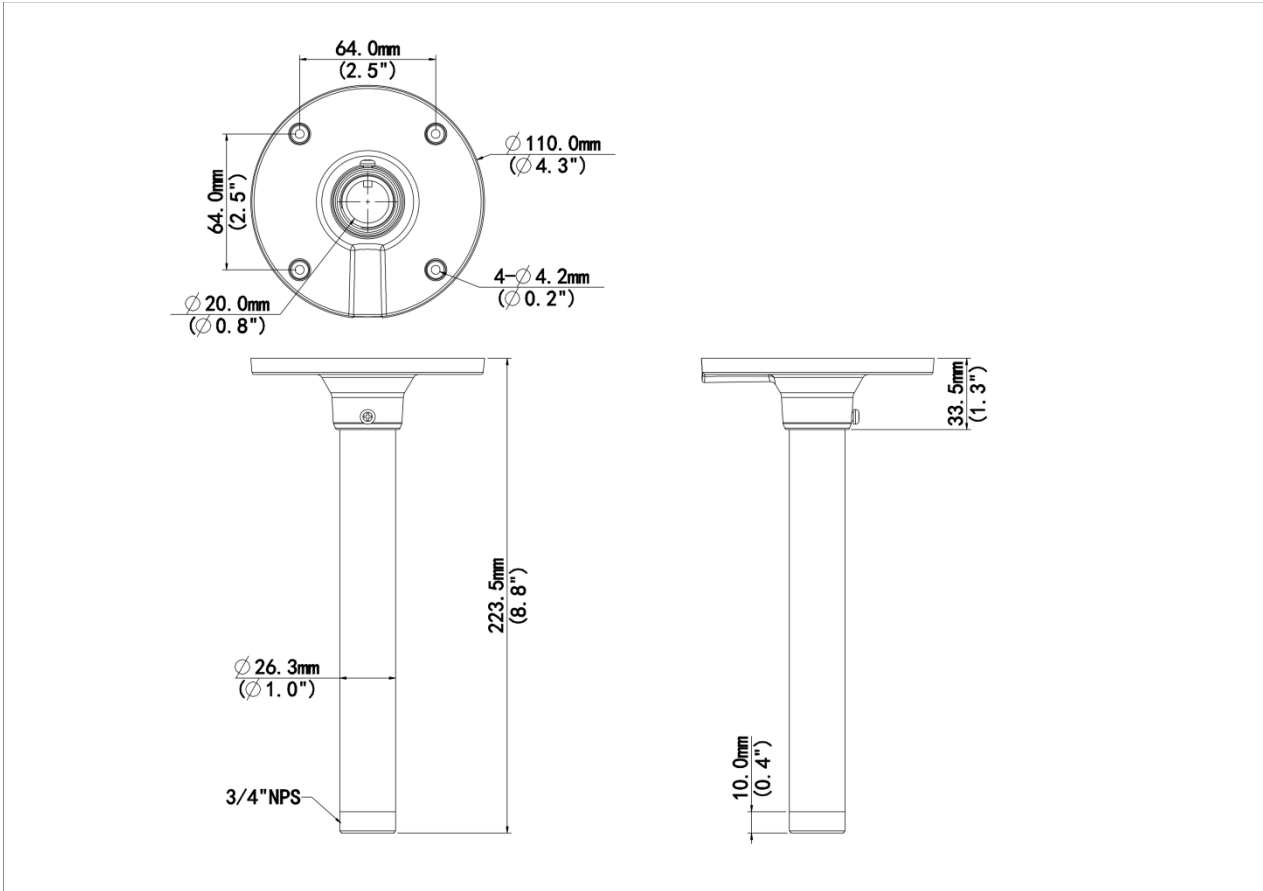

Accessories

TR-CM24-IN

TR-SE24-IN

TR-SE24-A-IN

Dome Pendant Mounting Bracket (Indoor)

Dome Pendant Mounting Pole 200mm

Dome Pendant Mounting Pole 500mm



TR-A01-IN

NPT 3/4" Waterproof Cable Gland



TR-JB08

Junction Box for 322x Dual-lens Dome



Zhejiang Uniview Technologies Co., Ltd.

No. 369, Xietong Road, Xixing Sub-district, Binjiang District, Hangzhou City, 310051, Zhejiang Province, China (Zhejiang) Pilot Free Trade Zone, China

Email: overseasbusiness@uniview.com; globalsupport@uniview.com

<http://www.uniview.com>

©2023-2025 Zhejiang Uniview Technologies Co., Ltd. All rights reserved.

*Product specifications and availability are subject to change without notice.

*Despite our best efforts, technical or typographical errors may exist in this document. Uniview cannot be held responsible for any such errors and reserves the right to change the contents of this document without prior notice.